

026 ~ 113

MULTI V *i*

MULTI V S

MULTI V M

MULTI V WATER 5
(Heat pump / Heat recovery)

OUTDOOR UNITS



MULTI V™ i

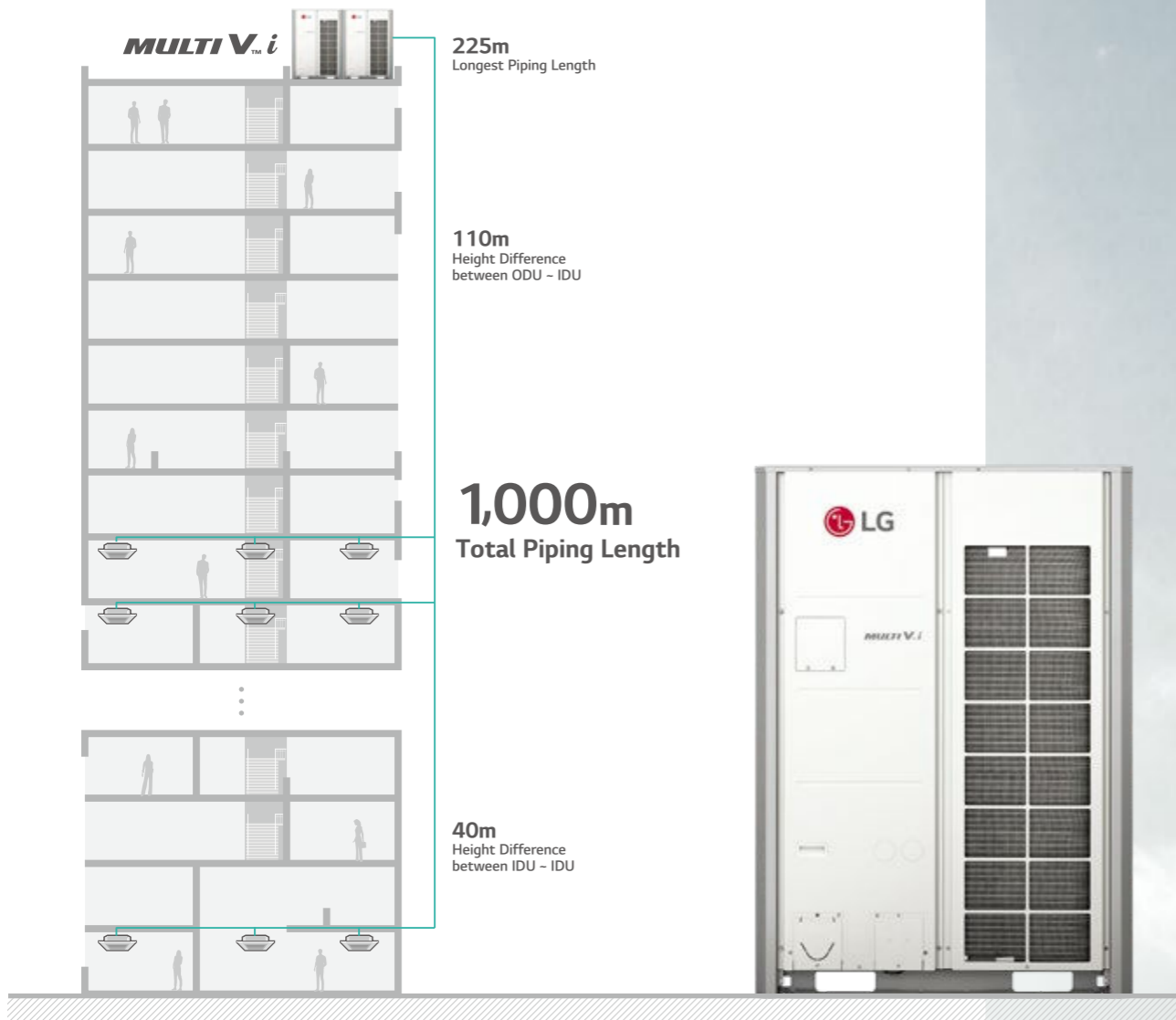

OUTDOOR UNITS
MULTI V i

Highlight



Energy savings



Reliability



Low noise



Advanced performance

- Air-cooled VRF Heat Pump & Heat Recovery
- 22.4kW - 268.8kW (Cooling capacity based)
- 30, 380 - 415V, 50Hz
- Top discharge outdoor unit
- Ability to function as Heat Pump or Heat Recovery

How does it work?



Dual Sensing



Partial Defrost

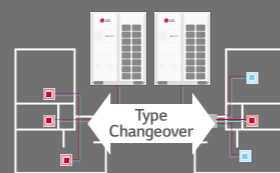

Interchangeable between
heat pump and heat recovery

01 INNOVATIVE

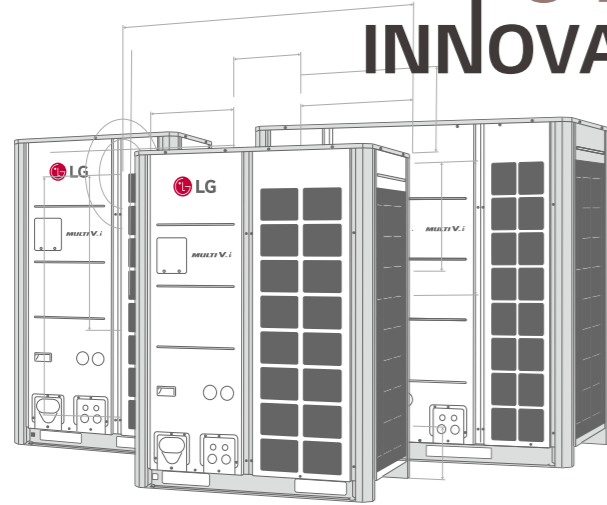

Innovative Energy efficiency / Performance realization

- Maximum 26HP for a Single Outdoor Unit
- Compact Design with Larger Capacity
- Powerful Performance
- Powerful Cooling Performance
- Powerful Heating Performance
- Newly Designed Compact Fan
- Flexible Outdoor Units Combination
- Corrosion Resistance

02 INTELLIGENT

Various environment recognition & optimized operation itself with AI Engine

AI EFFICIENCY UP

- AI Smart Care
- AI Energy Management

AI COMFORT UP

- Adaptive Noise Control
- Noise Target Control
- Weather Information Interlocking Control

AI SMART UP

- AI Smart Diagnosis
- Large Capacity Black Box
- Auto Tuning System
- Remote Upgrade System



03 INTERACTIVE

Upgrading & evolutionary system according to customer

- LG's Control Solution
- New Innovative Controller
- Smart GUI



Interlocking System

- A/C (Air Conditioner)
- LG AHU
- Valve / Pump AO (Analog Output)
- Occupancy Sensor / Alarm / Key-Tag DI (Digital Input)
- Fan / Lighting / Switch DO (Digital Output)
- Temperature / Humidity / CO₂ Sensor AI (Analog Input)



Maximum 26HP for a Single Outdoor Unit

LG MULTI V i saves space, time, and installation costs by offering a larger capacity single outdoor unit.



Compact Design with Larger Capacity

More area for the gardening on the roof and less architecture structure by less installation area and lighter outdoor units.



Install 260HP

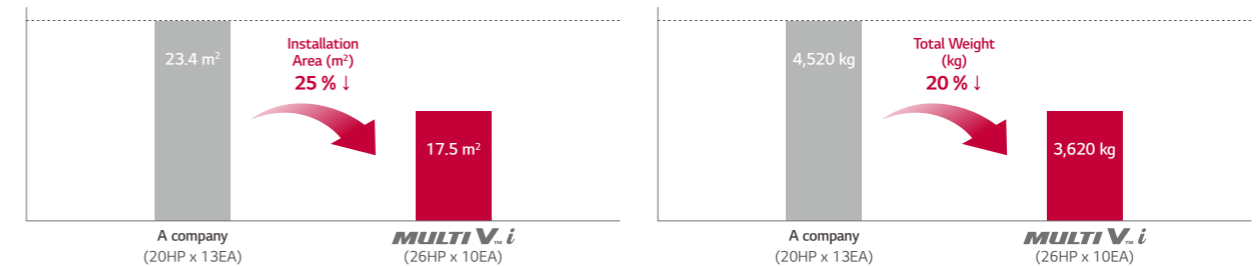

※ Previous model: ARUM261LTE5, New model: ARUM260LTE6
 ※ This scene is designed only for easier understanding, because 26HP unit cannot be applicable.

Powerful Performance

MULTI V 5 has already proved itself highly competitive in the European market in terms of efficiency levels, but MULTI V *i* exceeded its predecessor.

[Better than the Best]



※ For certain models in the line-up.

Powerful Cooling Performance

Reliable cooling operation up to 52°C, with full performance at 43°C. End users are able to enjoy comfortable indoor environment even in case of extreme weather conditions outside.



※ Final specifications may change slightly.

Powerful Heating Performance

More reliable heating operation is provided at down to -30°C and full performance at -10°C. Stable and heating performance is guaranteed even in case of an unexpected outdoor temperature drop.

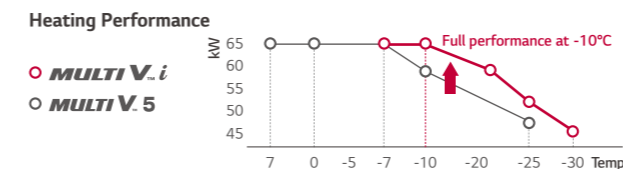

※ Final specifications may change slightly.

Stable & Powerful Heating

	MULTI V.i	MULTI V.5
Heating Operation Range	-30 ~ 16°C	-25 ~ 16°C
Performance at -10°C	Full	92 %

Improved design

Improved design for defrost by independent HEX system and accumulated freezing prevention design. With a differentiated structure and design, it provides longer heating time and reduced defrost time.

Continuous Heating

The heating operation duration was extended by independent HEX system for defrosting.

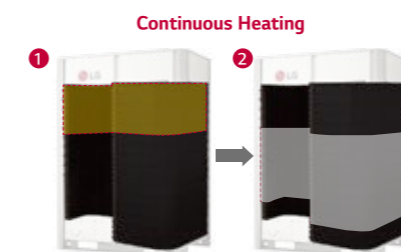
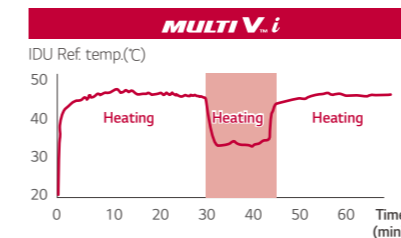
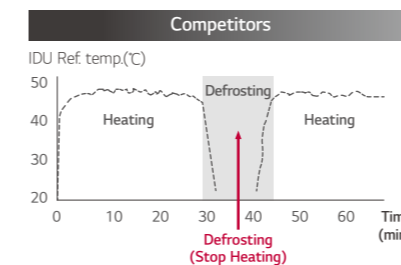

※ The defrost process is simplified for easier understanding.

NEW Accumulated Freezing Prevention Design

Preventing the freezing of the lower part of the heat exchanger



Defrost Time Reduction **65% ↓**
Indoor outlet air temperature deviation during heating minimum load operation **70% ↓**

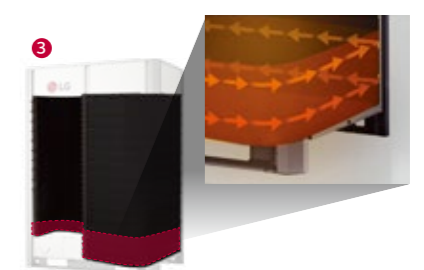

※ HEX: Heat Exchanger

Newly Designed Compact Fan

The design of a new biomimetic fan was inspired from nature. It brings more air volume and less noise with the same air flow rate compared to the conventional system.

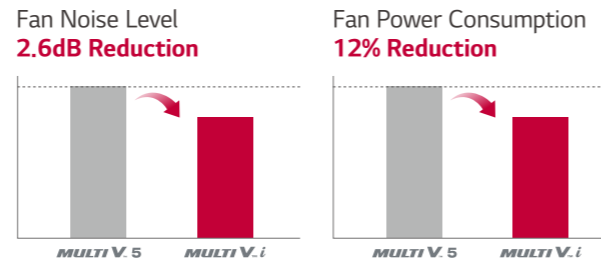

NEW Designed Biomimetic Fan
The new biomimetic fan has 6 blades that can reduce noise level and power consumption.



Compact Aero-Design
With an optimal air flow, the noise level and power consumption is reduced.

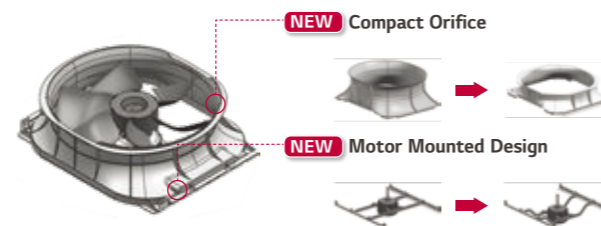

※ Final specifications may change slightly.

Flexible Outdoor Units Combination

Flexible combination can contribute to realize faster delivery and installation. It provides more options for designing according to customers' preferences.

Applicable Free Combination

2 Units : 28~36 HP
3 Units : 50~56 HP
4 Units : 70~76 HP

Standard Combination
18HP + 12HP

Flexible Combination
20HP + 10HP

Flexible Combination
16HP + 14HP

For Customer
Faster Delivery & Installation

For Consultant
Flexible Design for higher efficiency

※ The UXC chassis models are not applicable to free combination.
※ The 26 HP model of UXC chassis cannot be combined with other models.
※ More information can be checked in the LATS tool.

Corrosion Resistance

"Corrosion Resistance Black Fin" heat exchanger is designed for improved corrosion resistance. Body panels are also designed for improved corrosion resistance. 2,000 hours for body panels and 10,000 hours for heat exchanger make the product more reliable for customers.

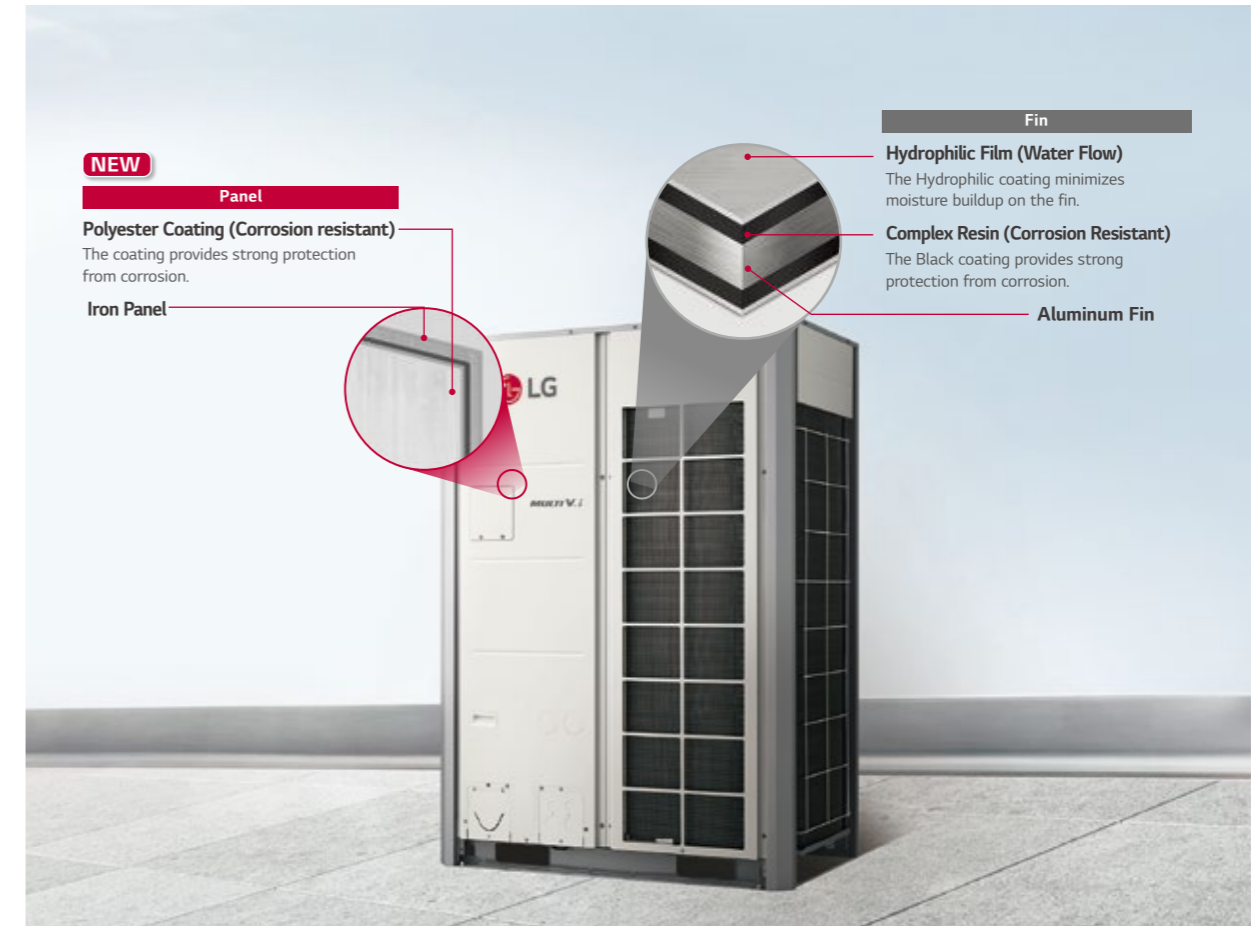

Salt Spray Test (SST) × Process repeated
5% Area of defects compared to initial state.



Salt Spray Test (SST) × Process repeated
5% Area of defects compared to initial state.



※ The product is not fully anticorrosive. To install near the sea, additional measures can be required.

AI Smart Care

MULTI V *i* is capable of autonomous adaptation to various situations. When no one is in the space, power saving mode automatically turns on. MULTI V *i* is equipped with deep learning algorithms enabling it to self-learn.

Data Collecting and Saving from IDU & ODU

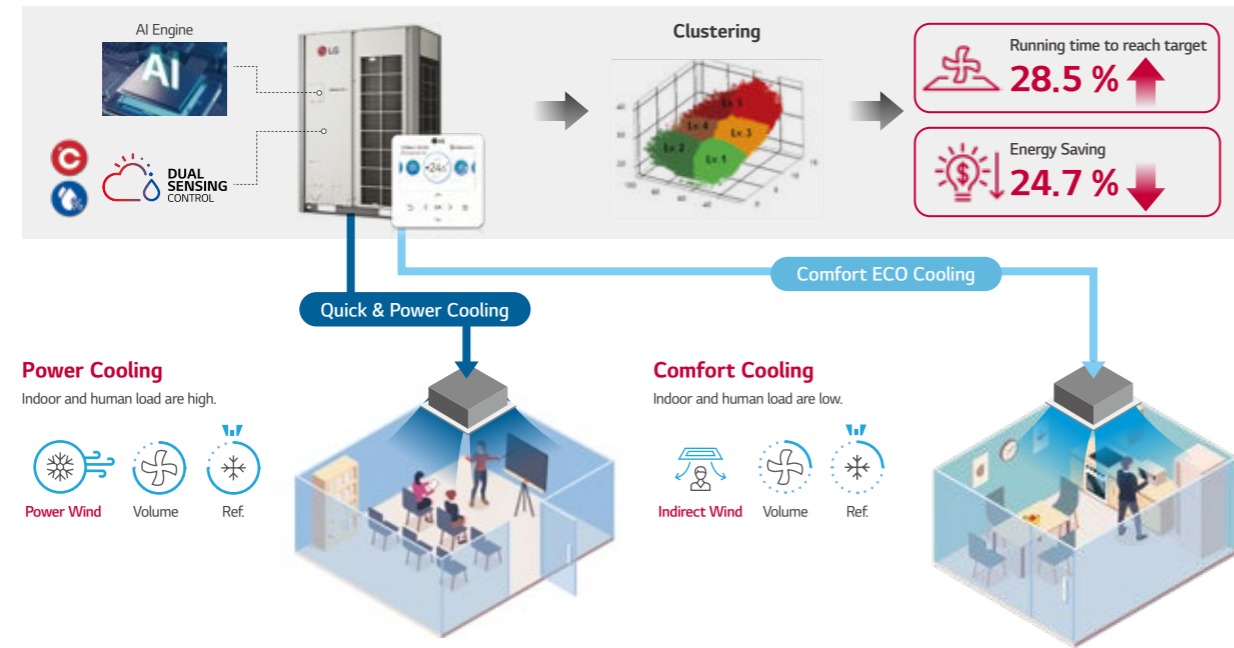

※ This is the result from internal test that is followed KS Test Standard, the result may be differed by applied model, local temperature, and environment.
- Model : MULTI V *i* 57 kW - Test Standard : KS B ISO15042

AI Energy Management

MULTI V *i* is able to preset monthly energy usage and consume power according to the target that has been previously set. By Comparing and analyzing previous power consumption of the current month and planned daily energy usage, overuse of the HVAC system operational costs can be prevented by AI Energy management.

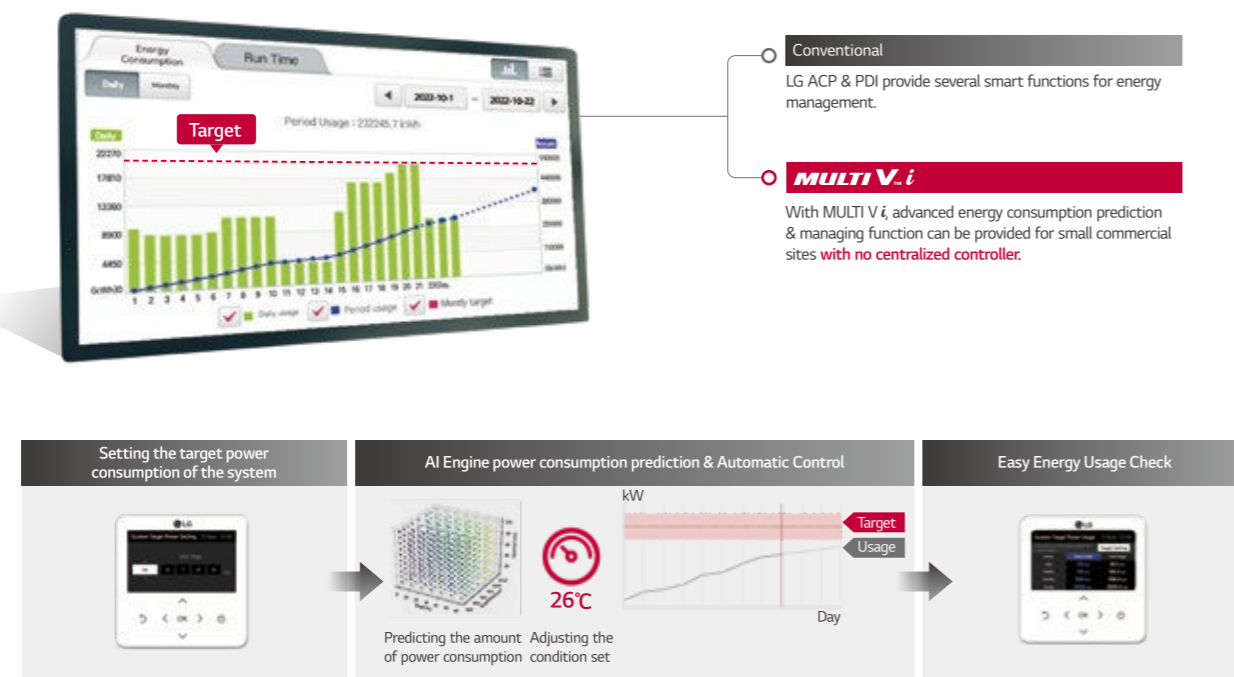

※ If more accurate status for energy consumption is needed, ACP and PDI have to be installed.

Adaptive Noise Control

The outdoor unit's noise level is automatically adjusted to the ambient conditions guaranteeing the customers' peace of mind, as they no longer have to worry about causing noise damage to neighbors.

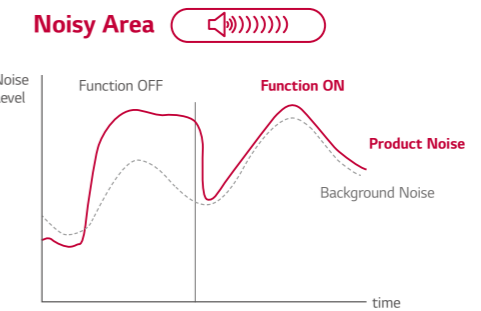
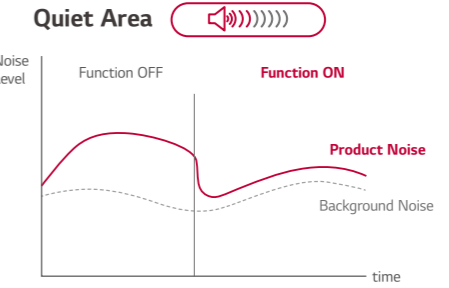
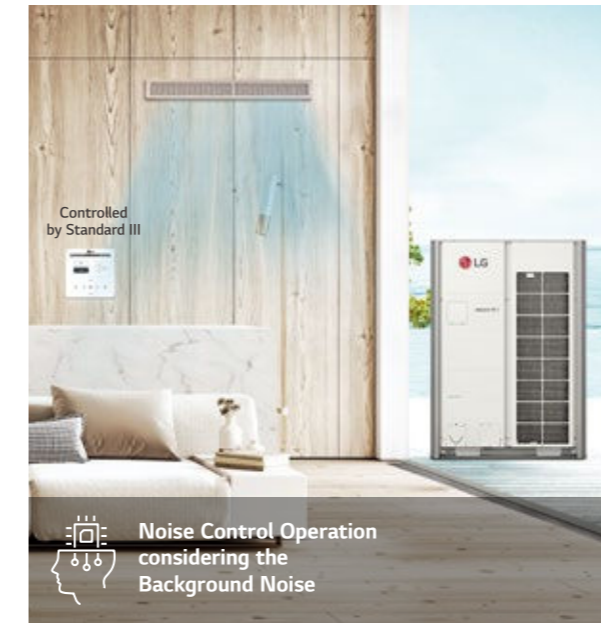

※ This function will be available in 1H. '24

Noise Target Control

The outdoor unit's noise can be restricted by the set sound level in advance, allowing customers to enjoy comfortable conditions while avoiding disturbing their neighbors and complying with the local noise regulations.

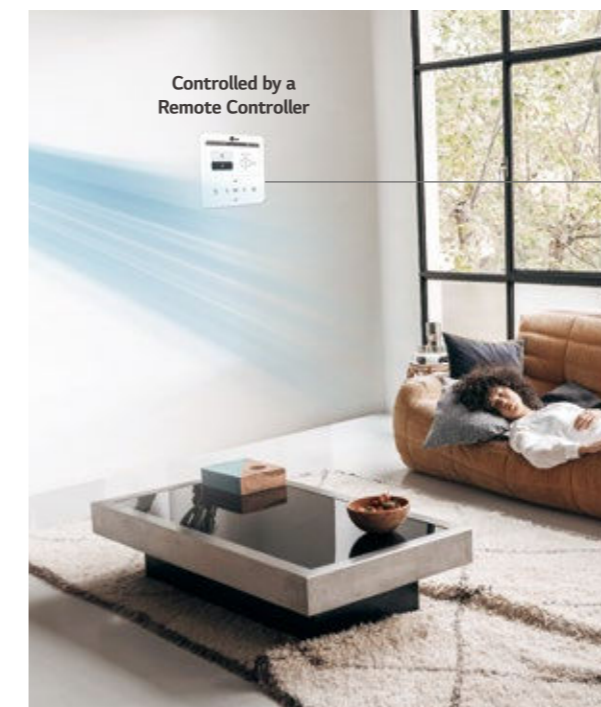

Available Setting
50 / 55 / 60 / 65 / 70 dB

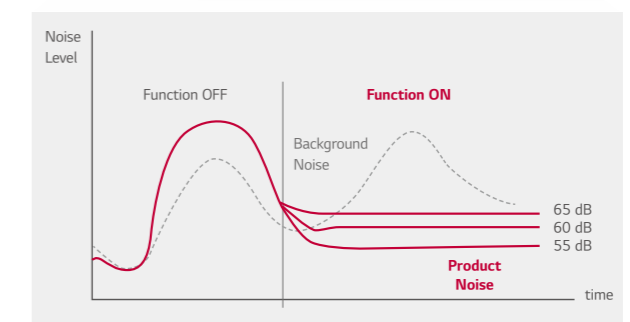

Weather Information Interlocking Control

LG MULTI V i provides more comfort and convenience by checking ambient weather conditions.

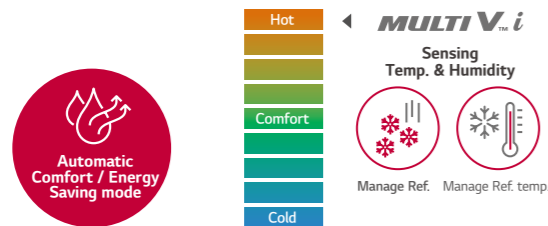
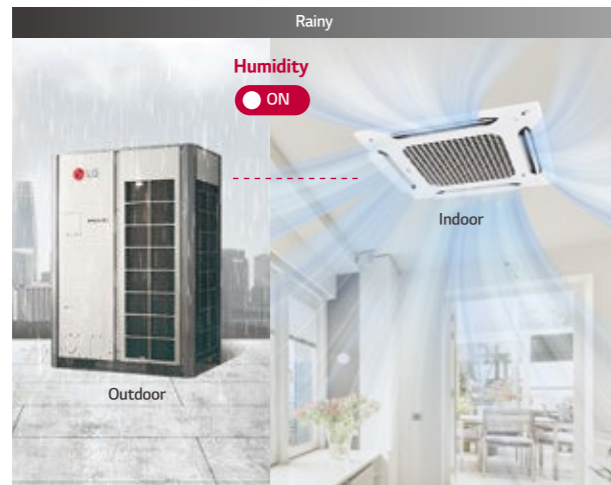

※ Connecting with the AccuWeather is needed the ThinQ server.
 ※ The operation is based on AccuWeather information.

AI Smart Diagnosis

AI Smart Diagnosis saves service time and provides for reliable LG MULTI V i operation by automatically analyzing and visualizing the product's performance status.

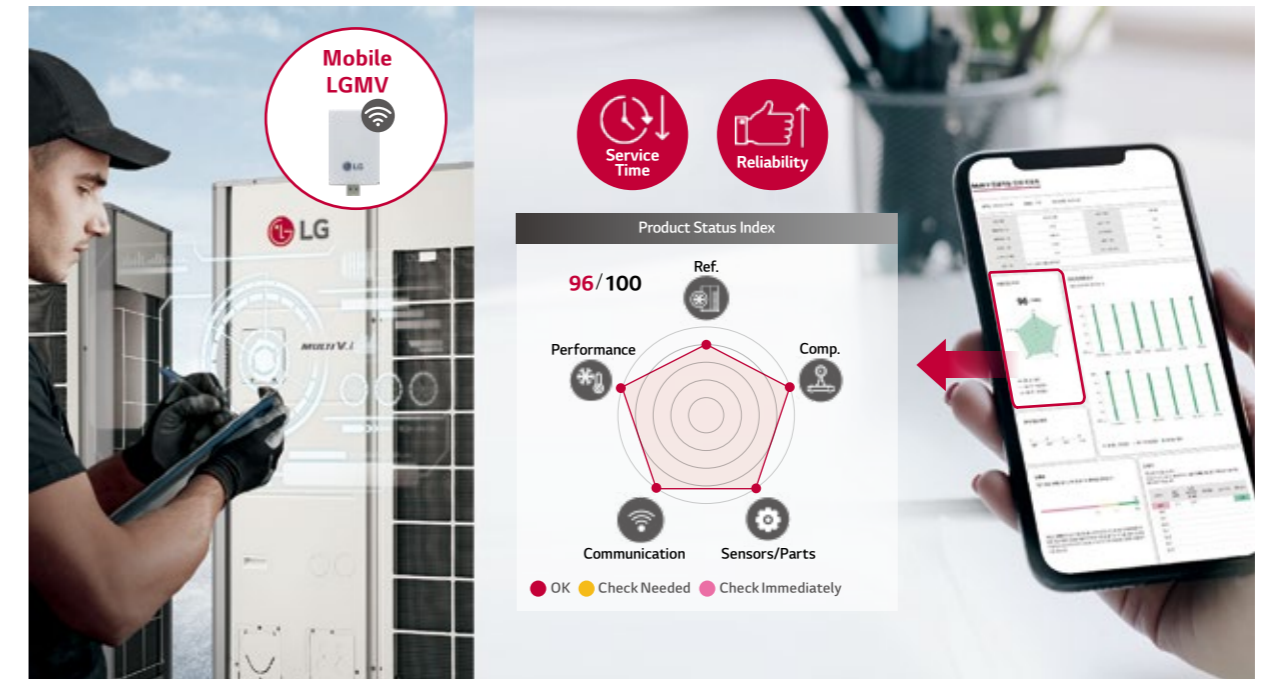

※ UI may be changed without notification.

Large Capacity Black Box

Operation data can be saved for up to 6 months before the system failure, contributing to quick service of the product.



※ UI may be changed without notification.

Auto Tuning System

LG MULTI V *i* provides a new experience to customers with faster and easier installation and service with AI engine which is automatically upgradable when the compressor and motor are replaced.



※ This function is to be applied to compressor and fan motor

Remote Upgrade System

Like a smart phone, LG MULTI V *i* upgrades itself remotely! You can opt for the latest version of software immediately without on-site service

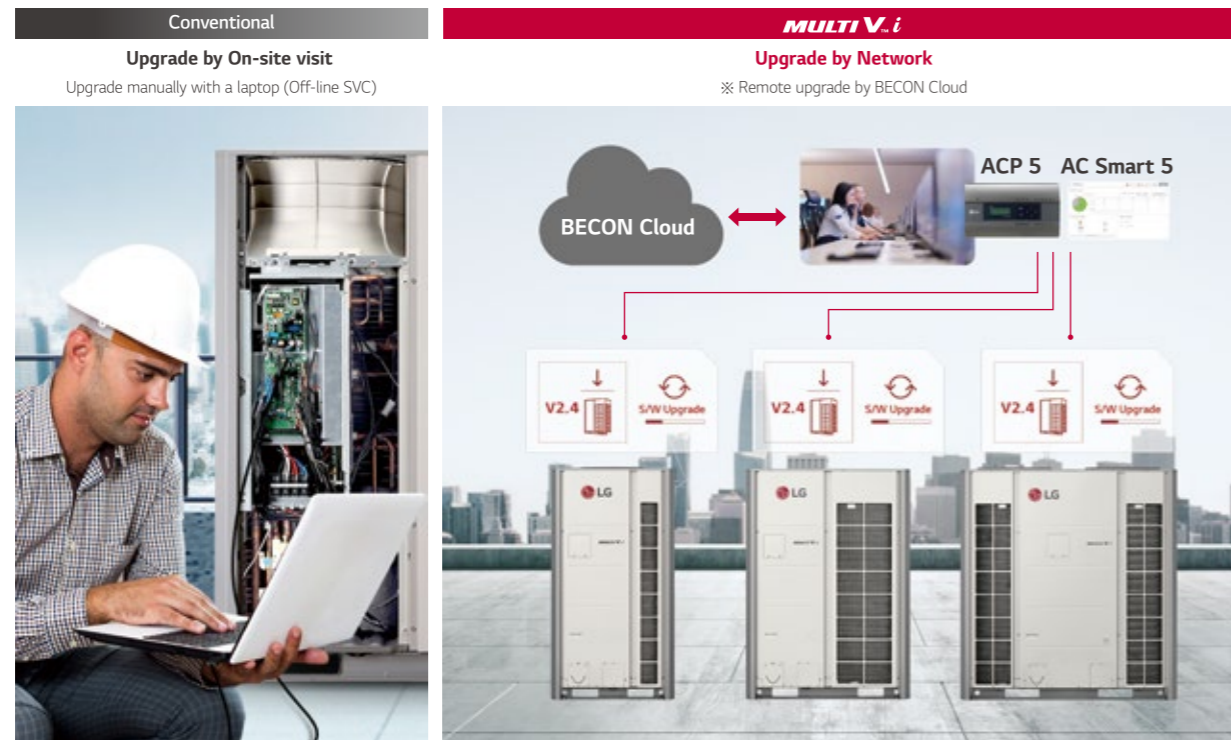

※ LG BECON Cloud is needed.

LG's Control Solution

LG MULTI V *i* offers diverse range of effective control solutions that satisfy specific needs of each building and its user scene.

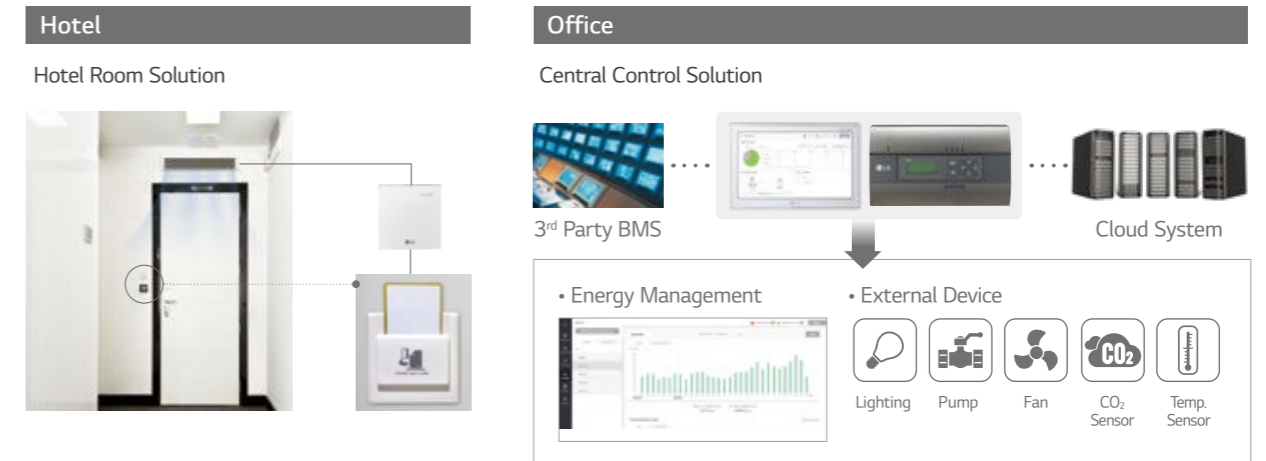

Smart GUI

Smart GUI allows remote management via various devices such as PC, tablet and smart phone.



Monitoring room
PC

Checking each room
Tablet

Working outside
Mobile



Schedule function



Energy Management



Operation Trending Report



Automatic E-mail Sending

New Innovative Controller

LG Deluxe remote controller provides better customer experience. (easy to use, E-saving and easy maintenance)



Features

- Installation wizard
- Built-in Wi-Fi with ThinQ Capability
- Humidity / Proximity sensor
- Seven (7) Day Scheduling with Mode - Home / Away / Sleep / Awake
- Function Code search Tool

* This remote controller will be available 1H, '23
 ※ UI may be changed without notification.

Full touch & Slim design

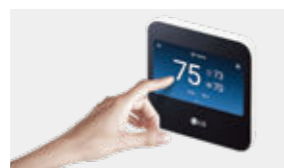

LG Deluxe has full touch LCD screen & slim design suitable for the residential application. In addition, user-oriented UX design enhances user convenience.

Air quality Monitoring

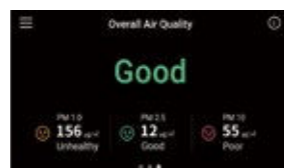

LG Deluxe can displays air quality status when air purifying device is installed. And also shows air quality monitoring history by day, week, month and year.

Pre-set Schedule



Seven Day scheduling with Home/Away/Sleep/Awake mode makes configuration much easier. And seasonal program setting offers more flexibility.

Energy Navigation

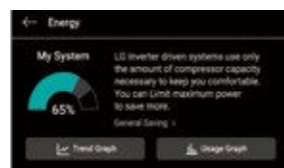

The Energy Navigation provides the system operation trend per day. Running time and power consumption is also provided compared to last year by week, month and year.

Remote Control



The built-in Wi-Fi module makes the connection to ThinQ cloud simple and easy. Seven day schedule is synchronized between ThinQ cloud and wired remote controller.

Easy Installation

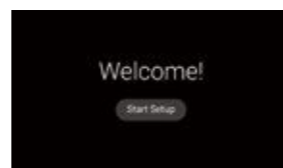

The installation wizard help the customer set up the basic configurations (Date & Time, Language, Temperature unit etc.) easily at the stage of installation.

AI Function Application

Category	Sub Category	Tool	Application	AI Function					
				AI Smart Care	AI Indoor Space care	Convenient Energy Check	AI Energy Target Control	AI Smart Diagnosis	Weather Information Interlocking Control
Cassette	1Way	TU,TT	N/A	X	X	X	X		X
	2Way	TS	`23.2H	●	●	●	●		●
	Dual Vane 4Way	TM-A, TP-B	`23.1H	●	●	●	●		●
	Round	TY	`23.1H	●	●	●	●		●
Console	Mini 4Way	TQ, TR	`24.1H	●	●	●	●		●
	QA	`23.2H	●	●	●	●		●	
Duct	Low Statics	L4, L5, L6	`23.1H	●	●	●	●		●
	High Statics	B8	`23.1H	●	●	●	●		●
	Mid Statics	M1, M2, M3	`23.2H	●	●	●	●	ODU Applicable	●
Floor Standing	CE, CF	`23.1H	●	●	●	●		●	
Fresh Air Intake	B8	`24.1H	X	X	●	●		●	
Convertible	Ceiling Suspended	VM1, VM2	`24.1H	●	●	●	●		●
	Ceiling & Floor	VE	`24.1H	●	●	●	●		●
Floor standing (PAC)	PT3, PF	`24.1H	●	X	●	●		●	
Wall Mounted	Artcool, Standard	SJ, SK, SV	`23.1H	●	●	●	●		●
	Gallery	SF	N/A	X	X	X	X		X
Hydro Kit	K1, K2, K3	`24.1H	X	X	●	●		●	

※ Some functions may not be available depending on the type of indoor unit.

Nomenclature

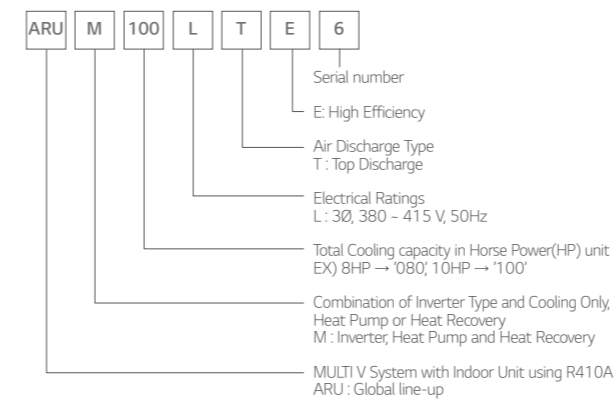

Position of Sound Pressure Level Measuring

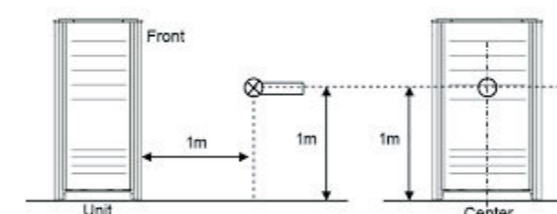

- Data is valid at diffuse field condition.
- Data is valid at nominal operating condition.
- Reference acoustic pressure 0dB = 20μPa.
- Sound pressure level is measured on the rated condition in the anechoic rooms by ISO 3745 standard. Refer to the model specifications for nominal conditions. (Power source and Ambient temperature, etc)
- Sound levels can be increased in accordance with installation and operating conditions.(Operating conditions include some functional condition like Static pressure mode, air guide use, Room target temperature setting, etc and these functions are different in accordance with each model.)
- Sound level will vary depending on a range of factors such as the construction(acoustic absorption coefficient) of particular room in which the equipment is installed.

Outdoor Units Function

Category	Functions	Value
Reliability	Defrost / Deicing	○
	High Pressure Switch	○
	Phase Protection	○
	Restart Delay (3-minutes)	○
	Self Diagnosis	○
	Soft Start	○
	Compressor Balanced Operation	○
	Test Function	○
	Night Low Noise Operation	○
	Peak Control	○
Convenience	Mode Lock	○
	SLC (Smart Load Control)	○
	Linear Bypass Cycle	○
	Noise Target Control	○
	Weather Information Interlocking Control	○
Special Functions	Comfort Cooling	○
	ODU Dry Contact Function	○
	High Static Pressure Compensation	○
	Continuous Cooling	○
	Continuous Heating (Partial Defrost)	○
	Convenient Energy Check	○
	Automatic Tuning Upgrade	○
	Remote Software Upgrade	○
	AI Smart Care	○
	AI Indoor Space Care	○
AI Energy Target Control	○	
AI Smart Diagnosis	○	

○ : Applied, X : Not applied
 - Accessory : Ordered and purchased separately the accessory package referring to the model name provided and install at field.
 - Accessory line-ups varies by region, so check your local catalogue or local sales material

Cooling / Heating Operation

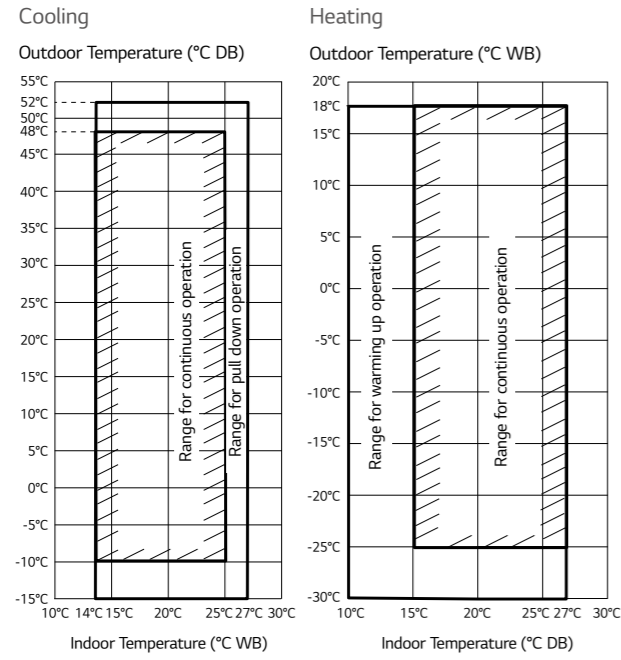

- Note
- These figures assume the following operating conditions: Equivalent piping length is standard condition, and level difference is 0m.
 - Range of pull down operation: If the relative humidity is too high, cooling capacity can be decreased by the sensible heat reduction.
 - Warming up operation means that the outdoor(outside) unit operates to reach the range of continuous operating, however it may not operate continuously due to safety or protection logic.

Simultaneous Cooling / Heating Operation

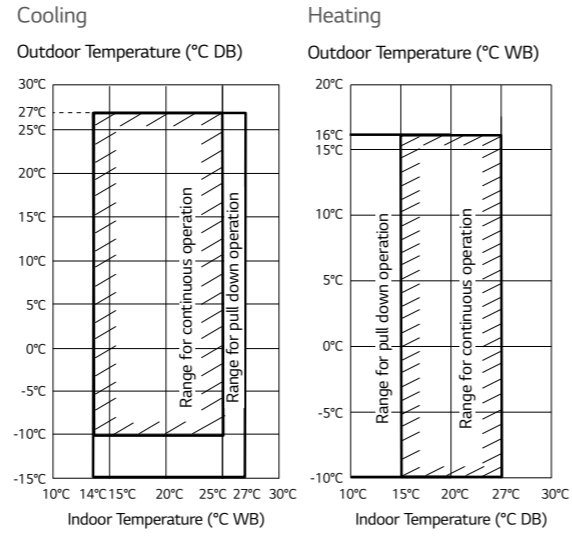

- Note
- These figures assume the following operating conditions: Equivalent piping length is standard condition, and level difference is 0m.
 - Range of pull down operation: If the relative humidity is too high, cooling capacity can be decreased by the sensible heat reduction.
 - Warming up operation means that the outdoor(outside) unit operates to reach the range of continuous operating, however it may not operate continuously due to safety or protection logic.

ARUM080LTE6 / ARUM100LTE6 / ARUM120LTE6

[Unit : mm]

No.	Part Name	Description
1	Leakage test hole (Side)	Ø22.2
2	Wire routing hole (Front)	2-Ø30
3	Wire routing hole (Bottom)	2-Ø22.2
4	Power cord routing hole (Front)	2-Ø45
5	Power cord routing hole (Bottom)	2-Ø50
6	Pipe routing hole (Front)	-
7	Pipe routing hole (Bottom)	-

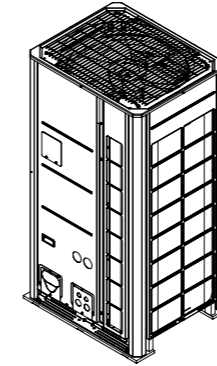

3D View

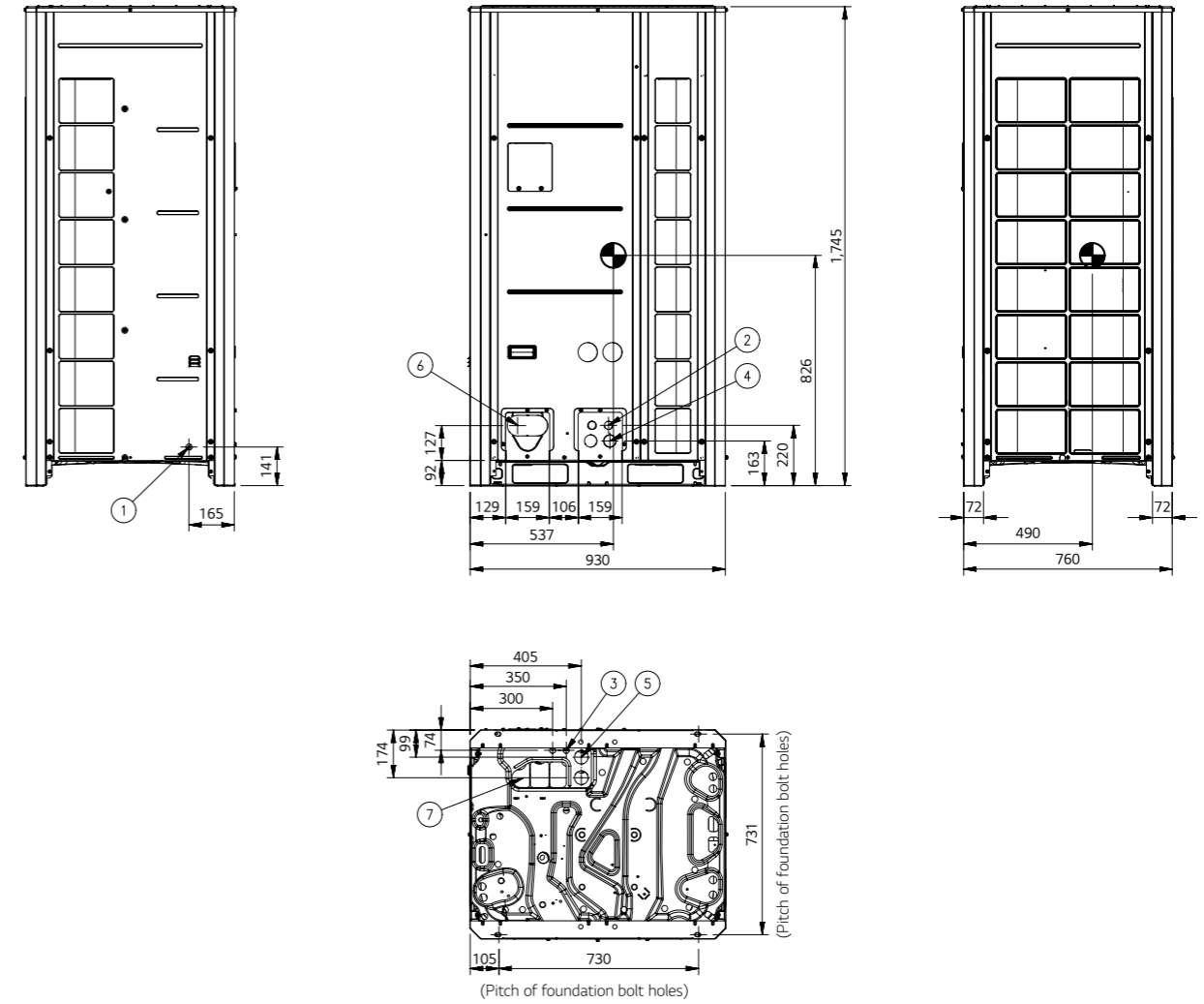
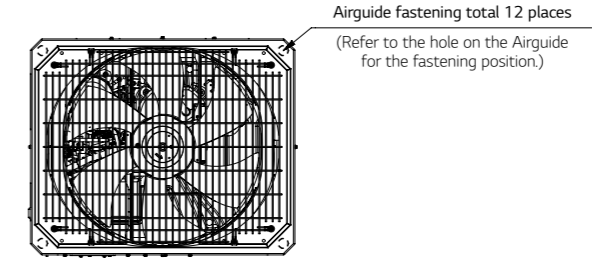

ARUM140LTE6 / ARUM160LTE6 /
ARUM180LTE6 / ARUM200LTE6 /

[Unit : mm]

No.	Part Name	Description
1	Leakage test hole (Side)	Ø22.2
2	Wire routing hole (Front)	2-Ø30
3	Wire routing hole (Bottom)	2-Ø22.2
4	Power cord routing hole (Front)	2-Ø45
5	Power cord routing hole (Bottom)	2-Ø50
6	Pipe routing hole (Front)	-
7	Pipe routing hole (Bottom)	-

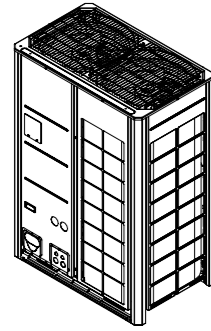

3D View

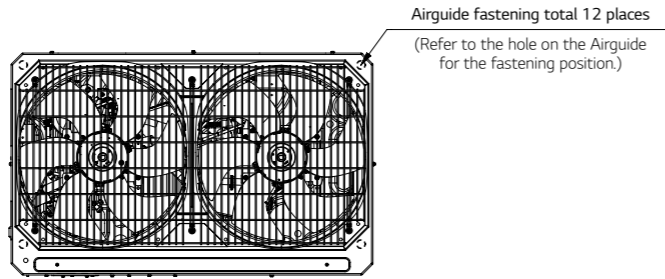

Airguide fastening total 12 places
(Refer to the hole on the Airguide for the fastening position.)

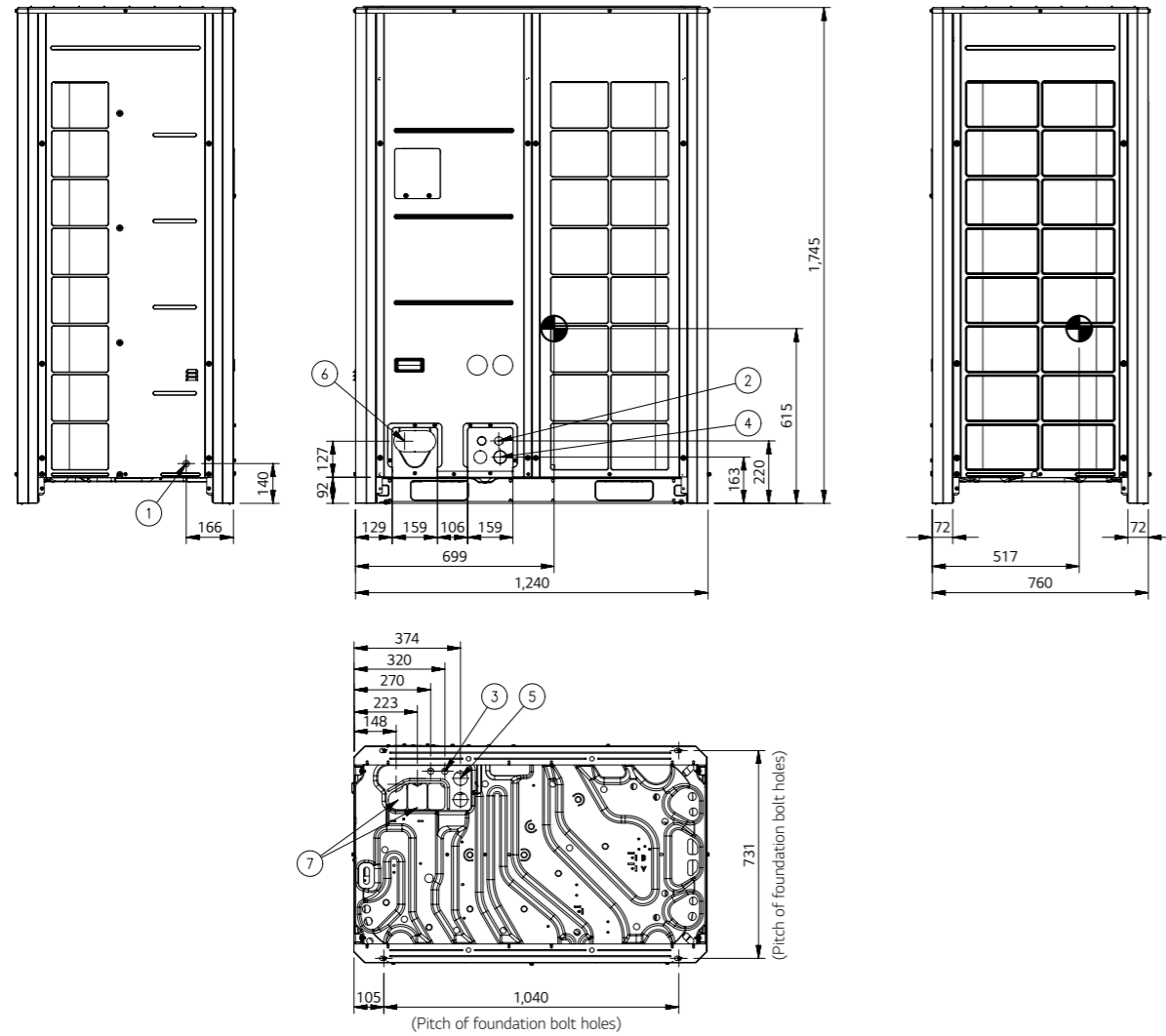

ARUM220LTE6 / ARUM240LTE6 /
ARUM260LTE6

[Unit : mm]

No.	Part Name	Description
1	Pipe routing hole (Bottom)	-
2	Pipe routing hole (Front)	-
3	Power cord routing hole (Front)	2-Ø30
4	Wire routing hole (Front)	2-Ø45

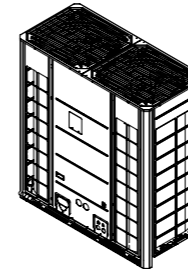

3D View

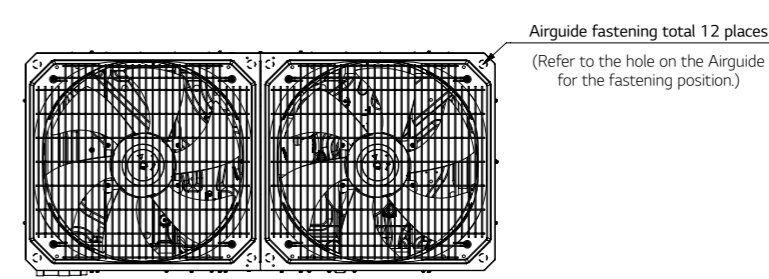

Airguide fastening total 12 places
(Refer to the hole on the Airguide for the fastening position.)

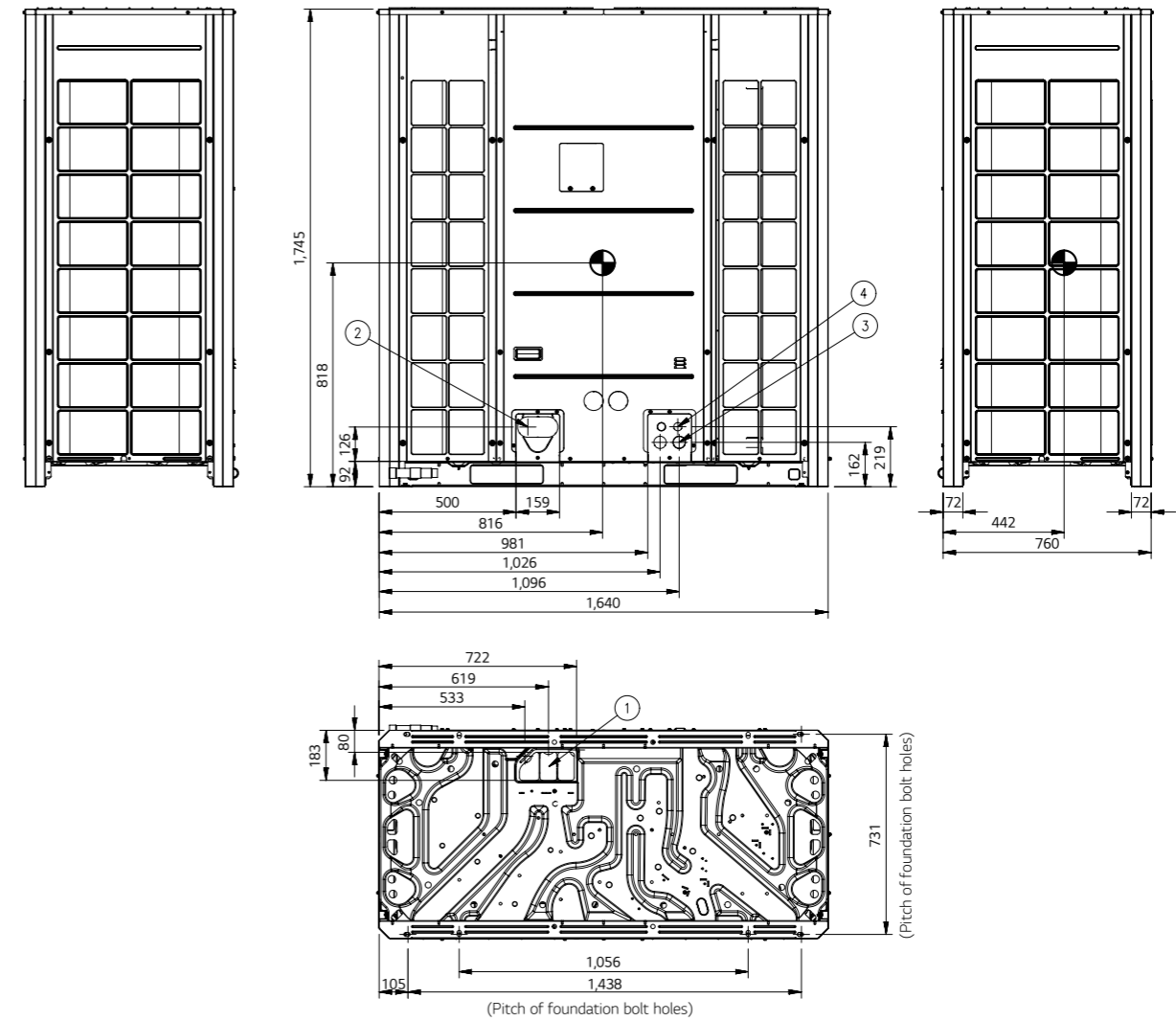

**ARUM080LTE6 / ARUM100LTE6
ARUM120LTE6 / ARUM140LTE6**

LG participates in the ECP programme for EUROVENT VRF program. Check ongoing validity of certification : www.eurovent-certification.com

HP			8	10	12	14
Classification	Chassis		UXA	UXA	UXA	UXB
	Combination Unit		ARUM080LTE6	ARUM100LTE6	ARUM120LTE6	ARUM140LTE6
Power Supply	V / Ø / Hz		380-415 / 3 / 50	380-415 / 3 / 50	380-415 / 3 / 50	380-415 / 3 / 50
Cooling Capacity	Rated	kW	22.4	28.0	33.6	39.2
	Rated	kW	22.4	28.0	33.6	39.2
Heating Capacity	Max	kW	25.2	31.5	37.8	44.1
	Rated	kW	6.10	8.33	11.65	11.88
Power Input (Cooling)	Rated	kW	5.16	6.22	7.77	8.43
	Rated	kW	5.16	6.22	7.77	8.43
Efficiency	EER (Rated)	W/W	3.67	3.36	2.88	3.30
	COP (Rated)	W/W	4.34	4.50	4.32	4.65
	SEER	Wh/Wh	8.28	8.11	7.94	8.55
	SCOP	Wh/Wh	4.45	4.52	4.99	5.17
Outdoor Fan	Type		Propeller Fan	Propeller Fan	Propeller Fan	Propeller Fan
	Air Flow Rate (High)	m³/min x No.	220 x 1	220 x 1	220 x 1	320 x 1
Outdoor Fan Motor	Discharge direction (Side / Top)		Top	Top	Top	Top
	Drive		Direct	Direct	Direct	Direct
Compressor	Type		Hermetically Sealed Scroll	Hermetically Sealed Scroll	Hermetically Sealed Scroll	Hermetically Sealed Scroll
	Piston Displacement	cm³/rev	62.1	62.1	62.1	62.1
Heat Exchanger	Number of Revolution	rev./min	3,600	3,600	3,600	3,600
	Motor Output	W x No.	5,300 x 1	5,300 x 1	5,300 x 1	5,300 x 1
Dimensions	Oil Type		FW68L (PVE)	FW68L (PVE)	FW68L (PVE)	FW68L (PVE)
	Fin Type		Wide Louver Plus	Wide Louver Plus	Wide Louver Plus	Wide Louver Plus
Weight	Net (W x H x D)	mm	930 x 1,745 x 760	930 x 1,745 x 760	930 x 1,745 x 760	1,240 x 1,745 x 760
	Shipping (W x H x D)	mm	965 x 1,919 x 802	965 x 1,919 x 802	965 x 1,919 x 802	1,282 x 1,919 x 802
Refrigerant	Net	kg	215	215	215	255
	Shipping	kg	225	225	225	265
Connecting Pipe	Type		R410A	R410A	R410A	R410A
	Precharged Amount	kg	8.5	9.5	9.5	13.0
Sound Pressure Level (Outdoor Unit)	t-CO ₂ eq.		17.744	19.831	19.831	27.138
	Control Type		EEV	EEV	EEV	EEV
Sound Power Level (Outdoor Unit)	Liquid	mm (inch)	Ø9.52 (3/8)	Ø9.52 (3/8)	Ø12.70 (1/2)	Ø12.70 (1/2)
	Gas	mm (inch)	Ø19.05 (3/4)	Ø22.20 (7/8)	Ø28.58 (1-1/8)	Ø28.58 (1-1/8)
Connectable Indoor Units Number	Low Pressure Gas (Heat Recovery)	mm (inch)	Ø19.05 (3/4)	Ø22.20 (7/8)	Ø28.58 (1-1/8)	Ø28.58 (1-1/8)
	High Pressure Gas (Heat Recovery)	mm (inch)	Ø15.88 (5/8)	Ø19.05 (3/4)	Ø19.05 (3/4)	Ø22.20 (7/8)
Communication Cable (VCTF-SB)	Cooling	dB (A)	57.0	57.5	59.0	60.0
	Heating	dB (A)	58.0	58.5	60.0	61.0
Connectable Indoor Units Number	Cooling	dB (A)	78.0	79.0	80.0	81.0
	Heating	dB (A)	78.0	79.0	82.0	81.0
Connectable Indoor Units Number	Communication Cable (VCTF-SB)	mm² x cores	0.75 - 1.5 x 2C	0.75 - 1.5 x 2C	0.75 - 1.5 x 2C	0.75 - 1.5 x 2C
	Max. (Conditional)	EA	13 (20)	16 (25)	20 (30)	23 (35)

1) Maximum numbers are prepared based on assumption that all 2.2kW indoor units are connected. The numbers in parentheses means maximum connectable indoor units in accordance with outdoor units combination (160% - 200%). The recommended ratio is 130%.

**ARUM160LTE6 / ARUM180LTE6
ARUM200LTE6 / ARUM220LTE6**

2) LG participates in the ECP programme for EUROVENT VRF program. Check ongoing validity of certification : www.eurovent-certification.com

HP			16	18	20	22
Classification	Chassis		UXB	UXB	UXB	UXC
	Combination Unit		ARUM160LTE6	ARUM180LTE6	ARUM200LTE6	ARUM220LTE6
Power Supply	V / Ø / Hz		380-415 / 3 / 50	380-415 / 3 / 50	380-415 / 3 / 50	380-415 / 3 / 50
Cooling Capacity	Rated	kW	44.8	50.4	56.0	61.6
	Rated	kW	44.8	50.4	56.0	61.6
Heating Capacity	Max	kW	50.4	56.7	63.0	69.3
	Rated	kW	15.45	14.39	17.54	22.00
Power Input (Cooling)	Rated	kW	10.09	10.59	12.64	15.96
	Rated	kW	10.09	10.59	12.64	15.96
Efficiency	EER (Rated)	W/W	2.90	3.50	3.19	2.80
	COP (Rated)	W/W	4.44	4.76	4.43	3.86
	SEER	Wh/Wh	7.97	8.65	8.42	7.20
	SCOP	Wh/Wh	5.46	4.81	5.13	4.62
Outdoor Fan	Type		Propeller Fan	Propeller Fan	Propeller Fan	Propeller Fan
	Air Flow Rate (High)	m³/min x No.	320 x 1	320 x 1	320 x 1	430 x 1
Outdoor Fan Motor	Discharge direction (Side / Top)		Top	Top	Top	Top
	Drive		Direct	Direct	Direct	Direct
Compressor	Type		Hermetically Sealed Scroll	Hermetically Sealed Scroll	Hermetically Sealed Scroll	Hermetically Sealed Scroll
	Piston Displacement	cm³/rev	62.1	62.1 x 2	62.1 x 2	62.1 x 2
Heat Exchanger	Number of Revolution	rev./min	3,600	3,600 x 2	3,600 x 2	3,600 x 2
	Motor Output	W x No.	5,300 x 1	5,300 x 2	5,300 x 2	5,300 x 2
Dimensions	Oil Type		FW68L (PVE)	FW68L (PVE)	FW68L (PVE)	FW68L (PVE)
	Fin Type		Wide Louver Plus	Wide Louver Plus	Wide Louver Plus	Wide Louver Plus
Weight	Net (W x H x D)	mm	1,240 x 1,745 x 760	1,240 x 1,745 x 760	1,240 x 1,745 x 760	1,640 x 1,745 x 760
	Shipping (W x H x D)	mm	1,282 x 1,919 x 802	1,282 x 1,919 x 802	1,282 x 1,919 x 802	1,675 x 1,919 x 787
Refrigerant	Net	kg	255	300	300	362
	Shipping	kg	265	310	310	372
Connecting Pipe	Type		R410A	R410A	R410A	R410A
	Precharged Amount	kg	13.0	16.0	16.0	16.0
Sound Pressure Level (Outdoor Unit)	t-CO ₂ eq.		27.138	33.400	33.400	33.400
	Control Type		EEV	EEV	EEV	EEV
Sound Power Level (Outdoor Unit)	Liquid	mm (inch)	Ø12.70 (1/2)	Ø15.88 (5/8)	Ø15.88 (5/8)	Ø15.88 (5/8)
	Gas	mm (inch)	Ø28.58 (1-1/8)	Ø28.58 (1-1/8)	Ø28.58 (1-1/8)	Ø28.58 (1-1/8)
Connectable Indoor Units Number	Low Pressure Gas (Heat Recovery)	mm (inch)	Ø28.58 (1-1/8)	Ø28.58 (1-1/8)	Ø28.58 (1-1/8)	Ø28.58 (1-1/8)
	High Pressure Gas (Heat Recovery)	mm (inch)	Ø22.20 (7/8)	Ø22.20 (7/8)	Ø22.20 (7/8)	Ø28.58 (1-1/8)
Communication Cable (VCTF-SB)	Cooling	dB (A)	60.5	61.0	62.0	64.0
	Heating	dB (A)	61.5	62.0	63.5	66.0
Connectable Indoor Units Number	Cooling	dB (A)	85.0	85.0	86.0	84.0
	Heating	dB (A)	85.0	86.0	89.0	88.0
Connectable Indoor Units Number	Communication Cable (VCTF-SB)	mm² x cores	0.75 - 1.5 x 2C	0.75 - 1.5 x 2C	0.75 - 1.5 x 2C	0.75 - 1.5 x 2C
	Max. (Conditional)	EA	26 (40)	29 (45)	32 (50)	35 (56)

1) Maximum numbers are prepared based on assumption that all 2.2kW indoor units are connected. The numbers in parentheses means maximum connectable indoor units in accordance with outdoor units combination (160% - 200%). The recommended ratio is 130%.

2) Applying to 16, 18, 20HP outdoor units only.

ARUM240LTE6 / ARUM260LTE6
ARUM280LTE6 / ARUM300LTE6



HP			24	26	28	30
Classification	Chassis		UXC	UXC	UXB + UXA	UXB + UXA
	Combination Unit		ARUM240LTE6	ARUM260LTE6	ARUM160LTE6 ARUM120LTE6	ARUM180LTE6 ARUM120LTE6
Power Supply	V / Ø / Hz		380-415 / 3 / 50	380-415 / 3 / 50	380-415 / 3 / 50	380-415 / 3 / 50
Cooling Capacity	Rated	kW	67.2	72.8	78.4	84.0
	Max	kW	75.6	81.9	88.2	94.5
Heating Capacity	Rated	kW	67.2	72.8	78.4	84.0
	Max	kW	75.6	81.9	88.2	94.5
Power Input (Cooling)	Rated	kW	26.15	31.52	27.10	26.04
Power Input (Heating)	Rated	kW	18.61	21.60	17.86	18.36
Efficiency	EER (Rated)	W/W	2.57	2.31	2.89	3.23
	COP (Rated)	W/W	3.61	3.37	4.39	4.58
	SEER	Wh/Wh	6.91	6.62	7.96	8.30
	SCOP	Wh/Wh	4.31	4.11	5.22	4.90
Outdoor Fan	Type		Propeller Fan	Propeller Fan	Propeller Fan	Propeller Fan
	Air Flow Rate (High)	m³/min x No.	430 x 1	430 x 1	(320 x 1) + (220 x 1)	(320 x 1) + (220 x 1)
	Discharge direction (Side / Top)		Top	Top	Top	Top
Outdoor Fan Motor	Drive		Direct	Direct	Direct	Direct
	Output	W x No.	1,500 x 2	1,500 x 2	(900 x 2) + (1,200 x 1)	(900 x 2) + (1,200 x 1)
Compressor	Type		Hermetically Sealed Scroll	Hermetically Sealed Scroll	Hermetically Sealed Scroll	Hermetically Sealed Scroll
	Piston Displacement	cm³/rev	62.1 x 2	62.1 x 2	62.1 x 2	62.1 x 3
	Number of Revolution	rev./min	3,600 x 2	3,600 x 2	3,600 x 2	3,600 x 3
	Motor Output	W x No.	5,300 x 2	5,300 x 2	5,300 x 2	5,300 x 3
	Oil Type		FW68L (PVE)	FW68L (PVE)	FW68L (PVE)	FW68L (PVE)
Heat Exchanger	Fin Type		Wide Louver Plus	Wide Louver Plus	Wide Louver Plus	Wide Louver Plus
Dimensions	Net (W x H x D)	mm	1,640 x 1,745 x 760	1,640 x 1,745 x 760	((1,240 x 1,745 x 760) x 1) + ((930 x 1,745 x 760) x 1)	((1,240 x 1,745 x 760) x 1) + ((930 x 1,745 x 760) x 1)
	Shipping (W x H x D)	mm	1,675 x 1,919 x 787	1,675 x 1,919 x 787	((1,282 x 1,919 x 802) x 1) + ((965 x 1,919 x 802) x 1)	((1,282 x 1,919 x 802) x 1) + ((965 x 1,919 x 802) x 1)
Weight	Net	kg	362	362	(255 x 1) + (215 x 1)	(300 x 1) + (215 x 1)
	Shipping	kg	372	372	(265 x 1) + (225 x 1)	(310 x 1) + (225 x 1)
Refrigerant	Type		R410A	R410A	R410A	R410A
	Precharged Amount	kg	16.0	16.0	22.5	25.5
	t-CO ₂ eq.		33.400	33.400	46.969	53.231
	Control Type		EEV	EEV	EEV	EEV
Connecting Pipe	Liquid	mm (inch)	Ø15.88 (5/8)	Ø19.05 (3/4)	Ø19.05 (3/4)	Ø19.05 (3/4)
	Gas	mm (inch)	Ø34.90 (1-3/8)	Ø34.90 (1-3/8)	Ø34.90 (1-3/8)	Ø34.90 (1-3/8)
	Low Pressure Gas (Heat Recovery)	mm (inch)	Ø34.90 (1-3/8)	Ø34.90 (1-3/8)	Ø34.90 (1-3/8)	Ø34.90 (1-3/8)
Sound Pressure Level (Outdoor Unit)	Cooling	dB (A)	65.0	65.0	62.8	63.1
	Heating	dB (A)	66.0	66.5	63.8	64.1
Sound Power Level (Outdoor Unit)	Cooling	dB (A)	85.0	89.0	86.2	86.2
	Heating	dB (A)	88.0	89.0	86.8	87.5
Connecting Cable	Communication Cable (VCTF-SB)	mm² x cores	0.75 - 1.5 x 2C	0.75 - 1.5 x 2C	0.75 - 1.5 x 2C	0.75 - 1.5 x 2C
Connectable Indoor Units Number	Max. (Conditional)	EA	39 (61)	42 (64)	45 (56)	49 (60)

1) Maximum numbers are prepared based on assumption that all 2.2kW indoor units are connected. The numbers in parentheses means maximum connectable indoor units in accordance with outdoor units combination (160% - 200%). The recommended ratio is 130%.

ARUM320LTE6 / ARUM340LTE6
ARUM360LTE6 / ARUM380LTE6



HP			32	34	36	38
Classification	Chassis		UXB + UXA	UXB + UXB	UXB + UXB	UXB + UXB
	Combination Unit		ARUM200LTE6 ARUM120LTE6	ARUM200LTE6 ARUM140LTE6	ARUM200LTE6 ARUM160LTE6	ARUM200LTE6 ARUM180LTE6
Power Supply	V / Ø / Hz		380-415 / 3 / 50	380-415 / 3 / 50	380-415 / 3 / 50	380-415 / 3 / 50
Cooling Capacity	Rated	kW	89.6	95.2	100.8	106.4
	Max	kW	100.8	107.1	113.4	119.7
Heating Capacity	Rated	kW	89.6	95.2	100.8	106.4
	Max	kW	100.8	107.1	113.4	119.7
Power Input (Cooling)	Rated	kW	29.19	29.42	32.99	31.93
Power Input (Heating)	Rated	kW	20.41	21.07	22.73	23.23
Efficiency	EER (Rated)	W/W	3.07	3.24	3.06	3.33
	COP (Rated)	W/W	4.39	4.52	4.43	4.58
	SEER	Wh/Wh	8.18	8.48	8.19	8.53
	SCOP	Wh/Wh	5.06	5.15	5.29	4.97
Outdoor Fan	Type		Propeller Fan	Propeller Fan	Propeller Fan	Propeller Fan
	Air Flow Rate (High)	m³/min x No.	(320 x 1) + (220 x 1)	(320 x 1) + (320 x 1)	(320 x 1) + (320 x 1)	(320 x 1) + (320 x 1)
	Discharge direction (Side / Top)		Top	Top	Top	Top
Outdoor Fan Motor	Drive		Direct	Direct	Direct	Direct
	Output	W x No.	(900 x 2) + (1,200 x 1)	(900 x 2) + (900 x 2)	(900 x 2) + (900 x 2)	(900 x 2) + (900 x 2)
Compressor	Type		Hermetically Sealed Scroll	Hermetically Sealed Scroll	Hermetically Sealed Scroll	Hermetically Sealed Scroll
	Piston Displacement	cm³/rev	62.1 x 3	62.1 x 3	62.1 x 3	62.1 x 4
	Number of Revolution	rev./min	3,600 x 3	3,600 x 3	3,600 x 3	3,600 x 4
	Motor Output	W x No.	5,300 x 3	5,300 x 3	5,300 x 3	5,300 x 4
	Oil Type		FW68L (PVE)	FW68L (PVE)	FW68L (PVE)	FW68L (PVE)
Heat Exchanger	Fin Type		Wide Louver Plus	Wide Louver Plus	Wide Louver Plus	Wide Louver Plus
Dimensions	Net (W x H x D)	mm	((1,240 x 1,745 x 760) x 1) + ((930 x 1,745 x 760) x 1)	(1,240 x 1,745 x 760) x 2	(1,240 x 1,745 x 760) x 2	(1,240 x 1,745 x 760) x 2
	Shipping (W x H x D)	mm	((1,282 x 1,919 x 802) x 1) + ((965 x 1,919 x 802) x 1)	(1,282 x 1,919 x 802) x 2	(1,282 x 1,919 x 802) x 2	(1,282 x 1,919 x 802) x 2
Weight	Net	kg	(300 x 1) + (215 x 1)	(300 x 1) + (255 x 1)	(300 x 1) + (255 x 1)	(300 x 1) + (300 x 1)
	Shipping	kg	(310 x 1) + (225 x 1)	(310 x 1) + (265 x 1)	(310 x 1) + (265 x 1)	(310 x 1) + (310 x 1)
Refrigerant	Type		R410A	R410A	R410A	R410A
	Precharged Amount	kg	25.5	29.0	29.0	32.0
	t-CO ₂ eq.		53.231	60.538	60.538	66.800
	Control Type		EEV	EEV	EEV	EEV
Connecting Pipe	Liquid	mm (inch)	Ø19.05 (3/4)	Ø19.05 (3/4)	Ø19.05 (3/4)	Ø19.05 (3/4)
	Gas	mm (inch)	Ø34.90 (1-3/8)	Ø34.90 (1-3/8)	Ø41.30 (1-5/8)	Ø41.30 (1-5/8)
	Low Pressure Gas (Heat Recovery)	mm (inch)	Ø34.90 (1-3/8)	Ø34.90 (1-3/8)	Ø41.30 (1-5/8)	Ø41.30 (1-5/8)
Sound Pressure Level (Outdoor Unit)	Cooling	dB (A)	63.8	64.1	64.3	64.5
	Heating	dB (A)	65.1	65.4	65.6	65.8
Sound Power Level (Outdoor Unit)	Cooling	dB (A)	87.0	87.2	88.5	88.5
	Heating	dB (A)	89.8	89.6	90.5	90.8
Connecting Cable	Communication Cable (VCTF-SB)	mm² x cores	0.75 - 1.5 x 2C	0.75 - 1.5 x 2C	0.75 - 1.5 x 2C	0.75 - 1.5 x 2C
Connectable Indoor Units Number	Max. (Conditional)	EA	52 (64)	55 (64)	58 (64)	61 (64)

1) Maximum numbers are prepared based on assumption that all 2.2kW indoor units are connected. The numbers in parentheses means maximum connectable indoor units in accordance with outdoor units combination (160% - 200%). The recommended ratio is 130%.

ARUM400LTE6 / ARUM420LTE6
ARUM440LTE6



HP		40	42	44	
Classification	Chassis	UXB + UXB	UXC + UXB	UXC + UXB	
	Combination Unit	ARUM200LTE6 ARUM200LTE6	ARUM220LTE6 ARUM200LTE6	ARUM240LTE6 ARUM200LTE6	
Power Supply	V / Ø / Hz	380-415 / 3 / 50	380-415 / 3 / 50	380-415 / 3 / 50	
Cooling Capacity	Rated	kW	112.0	117.6	
	Max	kW	126.0	132.3	
Heating Capacity	Rated	kW	112.0	117.6	
	Max	kW	126.0	132.3	
Power Input (Cooling)	Rated	kW	35.08	39.54	
Power Input (Heating)	Rated	kW	25.28	28.60	
Efficiency	EER (Rated)	W/W	3.19	2.97	
	COP (Rated)	W/W	4.43	4.11	
	SEER	Wh/Wh	8.42	7.81	
	SCOP	Wh/Wh	5.13	4.87	
Outdoor Fan	Type	Propeller Fan	Propeller Fan	Propeller Fan	
	Air Flow Rate (High)	m ³ /min x No.	(320 x 1) + (320 x 1)	(430 x 1) + (320 x 1)	(430 x 1) + (320 x 1)
	Discharge direction (Side / Top)		Top	Top	Top
Outdoor Fan Motor	Drive	Direct	Direct	Direct	
	Output	W x No.	(900 x 2) + (900 x 2)	(1,500 x 2) + (900 x 2)	(1,500 x 2) + (900 x 2)
Compressor	Type	Hermetically Sealed Scroll	Hermetically Sealed Scroll	Hermetically Sealed Scroll	
	Piston Displacement	cm ³ /rev	62.1 x 4	62.1 x 4	62.1 x 4
	Number of Revolution	rev./min	3,600 x 4	3,600 x 4	3,600 x 4
	Motor Output	W x No.	5,300 x 4	5,300 x 4	5,300 x 4
	Oil Type		FW68L (PVE)	FW68L (PVE)	FW68L (PVE)
Heat Exchanger	Fin Type	Wide Louver Plus	Wide Louver Plus	Wide Louver Plus	
	Net (W x H x D)	mm	(1,240 x 1,745 x 760) x 2	((1,640 x 1,745 x 760) x 1) + ((1,240 x 1,745 x 760) x 1)	((1,640 x 1,745 x 760) x 1) + ((1,240 x 1,745 x 760) x 1)
Dimensions	Shipping (W x H x D)	mm	(1,282 x 1,919 x 802) x 2	((1,675 x 1,919 x 802) x 1) + ((1,282 x 1,919 x 802) x 1)	((1,675 x 1,919 x 802) x 1) + ((1,282 x 1,919 x 802) x 1)
	Net	kg	(300 x 1) + (300 x 1)	(362 x 1) + (300 x 1)	(362 x 1) + (300 x 1)
Weight	Shipping	kg	(310 x 1) + (310 x 1)	(372 x 1) + (310 x 1)	(372 x 1) + (310 x 1)
	Type		R410A	R410A	R410A
Refrigerant	Precharged Amount	kg	32.0	32.0	32.0
	t-CO ₂ eq.		66.800	66.800	66.800
	Control Type		EEV	EEV	EEV
	Liquid	mm (inch)	Ø19.05 (3/4)	Ø19.05 (3/4)	Ø19.05 (3/4)
Connecting Pipe	Gas	mm (inch)	Ø41.30 (1-5/8)	Ø41.30 (1-5/8)	Ø41.30 (1-5/8)
	Low Pressure Gas (Heat Recovery)	mm (inch)	Ø41.30 (1-5/8)	Ø41.30 (1-5/8)	Ø41.30 (1-5/8)
	High Pressure Gas (Heat Recovery)	mm (inch)	Ø34.90 (1-3/8)	Ø34.90 (1-3/8)	Ø34.90 (1-3/8)
	Sound Pressure Level (Outdoor Unit)	Cooling	dB (A)	65.0	66.1
Sound Power Level (Outdoor Unit)	Heating	dB (A)	66.5	67.9	67.9
	Cooling	dB (A)	89.0	88.1	88.5
Connecting Cable	Communication Cable (VCTF-SB)	mm ² x cores	0.75 - 1.5 x 2C	0.75 - 1.5 x 2C	0.75 - 1.5 x 2C
	Connectable Indoor Units Number	Max. (Conditional)	EA	64	64

1) Maximum numbers are prepared based on assumption that all 2.2kW indoor units are connected. The numbers in parentheses means maximum connectable indoor units in accordance with outdoor units combination (160% - 200%). The recommended ratio is 130%.

ARUM460LTE6 / ARUM480LTE6
ARUM500LTE6



HP		46	48	50	
Classification	Chassis	UXC + UXC	UXC + UXC	UXB + UXB + UXA	
	Combination Unit	ARUM240LTE6 ARUM220LTE6	ARUM240LTE6 ARUM240LTE6	ARUM200LTE6 ARUM180LTE6 ARUM120LTE6	
Power Supply	V / Ø / Hz	380-415 / 3 / 50	380-415 / 3 / 50	380-415 / 3 / 50	
Cooling Capacity	Rated	kW	128.8	134.4	
	Max	kW	144.9	151.2	
Heating Capacity	Rated	kW	128.8	134.4	
	Max	kW	144.9	151.2	
Power Input (Cooling)	Rated	kW	48.15	52.30	
Power Input (Heating)	Rated	kW	34.57	37.22	
Efficiency	EER (Rated)	W/W	2.67	2.57	
	COP (Rated)	W/W	3.73	3.61	
	SEER	Wh/Wh	7.06	6.91	
	SCOP	Wh/Wh	4.47	4.31	
Outdoor Fan	Type	Propeller Fan	Propeller Fan	Propeller Fan	
	Air Flow Rate (High)	m ³ /min x No.	(430 x 1) + (430 x 1)	(430 x 1) + (430 x 1)	(320 x 1) + (320 x 1) + (220 x 1)
	Discharge direction (Side / Top)		Top	Top	Top
Outdoor Fan Motor	Drive	Direct	Direct	Direct	
	Output	W x No.	(1,500 x 2) + (1,500 x 2)	(1,500 x 2) + (1,500 x 2)	(900 x 2) + (900 x 2) + (1,200 x 1)
Compressor	Type	Hermetically Sealed Scroll	Hermetically Sealed Scroll	Hermetically Sealed Scroll	
	Piston Displacement	cm ³ /rev	62.1 x 4	62.1 x 4	62.1 x 5
	Number of Revolution	rev./min	3,600 x 4	3,600 x 4	3,600 x 5
	Motor Output	W x No.	5,300 x 4	5,300 x 4	5,300 x 5
	Oil Type		FW68L (PVE)	FW68L (PVE)	FW68L (PVE)
Heat Exchanger	Fin Type	Wide Louver Plus	Wide Louver Plus	Wide Louver Plus	
	Net (W x H x D)	mm	(1,640 x 1,745 x 760) x 2	(1,640 x 1,745 x 760) x 2	((1,240 x 1,745 x 760) x 2) + ((930 x 1,745 x 760) x 1)
Dimensions	Shipping (W x H x D)	mm	(1,675 x 1,919 x 802) x 2	(1,675 x 1,919 x 802) x 2	((1,282 x 1,919 x 802) x 2) + ((965 x 1,919 x 802) x 1)
	Net	kg	(362 x 1) + (362 x 1)	(362 x 1) + (362 x 1)	(300 x 1) + (300 x 1) + (215 x 1)
Weight	Shipping	kg	(372 x 1) + (372 x 1)	(372 x 1) + (372 x 1)	(310 x 1) + (310 x 1) + (225 x 1)
	Type		R410A	R410A	R410A
Refrigerant	Precharged Amount	kg	32.0	32.0	41.5
	t-CO ₂ eq.		66.800	66.800	86.631
	Control Type		EEV	EEV	EEV
	Liquid	mm (inch)	Ø19.05 (3/4)	Ø19.05 (3/4)	Ø19.05 (3/4)
Connecting Pipe	Gas	mm (inch)	Ø41.30 (1-5/8)	Ø41.30 (1-5/8)	Ø41.30 (1-5/8)
	Low Pressure Gas (Heat Recovery)	mm (inch)	Ø41.30 (1-5/8)	Ø41.30 (1-5/8)	Ø41.30 (1-5/8)
	High Pressure Gas (Heat Recovery)	mm (inch)	Ø34.90 (1-3/8)	Ø34.90 (1-3/8)	Ø34.90 (1-3/8)
	Sound Pressure Level (Outdoor Unit)	Cooling	dB (A)	67.5	68.0
Sound Power Level (Outdoor Unit)	Heating	dB (A)	69.0	69.0	66.8
	Cooling	dB (A)	87.5	88.0	89.1
Connecting Cable	Communication Cable (VCTF-SB)	mm ² x cores	0.75 - 1.5 x 2C	0.75 - 1.5 x 2C	0.75 - 1.5 x 2C
	Connectable Indoor Units Number	Max. (Conditional)	EA	64	64

1) Maximum numbers are prepared based on assumption that all 2.2kW indoor units are connected. The numbers in parentheses means maximum connectable indoor units in accordance with outdoor units combination (160% - 200%). The recommended ratio is 130%.

ARUM52OLTE6 / ARUM54OLTE6
ARUM56OLTE6



HP			52	54	56
Classification	Chassis		UXB + UXB + UXA	UXB + UXB + UXB	UXB + UXB + UXB
	Combination Unit		ARUM200LTE6 ARUM200LTE6 ARUM120LTE6	ARUM200LTE6 ARUM200LTE6 ARUM140LTE6	ARUM200LTE6 ARUM200LTE6 ARUM160LTE6
Power Supply	V / Ø / Hz		380-415 / 3 / 50	380-415 / 3 / 50	380-415 / 3 / 50
Cooling Capacity	Rated	kW	145.6	151.2	156.8
	Heating Capacity	Rated	kW	145.6	151.2
Heating Capacity	Max	kW	163.8	170.1	176.4
	Power Input (Cooling)	Rated	kW	46.73	46.96
Power Input (Heating)	Rated	kW	33.05	33.71	35.37
Efficiency	EER (Rated)	W/W	3.12	3.22	3.10
	COP (Rated)	W/W	4.41	4.49	4.43
	SEER	Wh/Wh	8.26	8.46	8.27
	SCOP	Wh/Wh	5.08	5.14	5.24
Outdoor Fan	Type		Propeller Fan	Propeller Fan	Propeller Fan
	Air Flow Rate (High)	m³/min x No.	(320 x 1) + (320 x 1) + (220 x 1)	(320 x 1) + (320 x 1) + (320 x 1)	(320 x 1) + (320 x 1) + (320 x 1)
	Discharge direction (Side / Top)		Top	Top	Top
Outdoor Fan Motor	Drive		Direct	Direct	Direct
	Output	W x No.	(900 x 2) + (900 x 2) + (1,200 x 1)	(900 x 2) + (900 x 2) + (900 x 2)	(900 x 2) + (900 x 2) + (900 x 2)
Compressor	Type		Hermetically Sealed Scroll	Hermetically Sealed Scroll	Hermetically Sealed Scroll
	Piston Displacement	cm³/rev	62.1 x 5	62.1 x 5	62.1 x 5
	Number of Revolution	rev./min	3,600 x 5	3,600 x 5	3,600 x 5
	Motor Output	W x No.	5,300 x 5	5,300 x 5	5,300 x 5
	Oil Type		FW68L (PVE)	FW68L (PVE)	FW68L (PVE)
Heat Exchanger	Fin Type		Wide Louver Plus	Wide Louver Plus	Wide Louver Plus
Dimensions	Net (W x H x D)	mm	((1,240 x 1,745 x 760) x 2) + ((930 x 1,745 x 760) x 1)	(1,240 x 1,745 x 760) x 3	(1,240 x 1,745 x 760) x 3
	Shipping (W x H x D)	mm	((1,282 x 1,919 x 802) x 2) + ((965 x 1,919 x 802) x 1)	(1,282 x 1,919 x 802) x 3	(1,282 x 1,919 x 802) x 3
Weight	Net	kg	(300 x 1) + (300 x 1) + (215 x 1)	(300 x 1) + (300 x 1) + (255 x 1)	(300 x 1) + (300 x 1) + (255 x 1)
	Shipping	kg	(310 x 1) + (310 x 1) + (225 x 1)	(310 x 1) + (310 x 1) + (265 x 1)	(310 x 1) + (310 x 1) + (265 x 1)
Refrigerant	Type		R410A	R410A	R410A
	Precharged Amount	kg	41.5	45.0	45.0
	t-CO ₂ eq.		86.631	93.938	93.938
	Control Type		EEV	EEV	EEV
Connecting Pipe	Liquid	mm (inch)	Ø19.05 (3/4)	Ø19.05 (3/4)	Ø19.05 (3/4)
	Gas	mm (inch)	Ø41.30 (1-5/8)	Ø41.30 (1-5/8)	Ø41.30 (1-5/8)
	Low Pressure Gas (Heat Recovery)	mm (inch)	Ø41.30 (1-5/8)	Ø41.30 (1-5/8)	Ø41.30 (1-5/8)
	High Pressure Gas (Heat Recovery)	mm (inch)	Ø34.90 (1-3/8)	Ø34.90 (1-3/8)	Ø34.90 (1-3/8)
Sound Pressure Level (Outdoor Unit)	Cooling	dB (A)	66.0	66.2	66.3
	Heating	dB (A)	67.4	67.6	67.7
Sound Power Level (Outdoor Unit)	Cooling	dB (A)	89.5	89.6	90.5
	Heating	dB (A)	92.4	92.3	92.8
Connecting Cable	Communication Cable (VCTF-SB)	mm² x cores	0.75 - 1.5 x 2C	0.75 - 1.5 x 2C	0.75 - 1.5 x 2C
Connectable Indoor Units Number	Max. (Conditional)	EA	64	64	64

1) Maximum numbers are prepared based on assumption that all 2.2kW indoor units are connected. The numbers in parentheses means maximum connectable indoor units in accordance with outdoor units combination (160% - 200%). The recommended ratio is 130%.

ARUM58OLTE6 / ARUM60OLTE6
ARUM62OLTE6



HP			58	60	62
Classification	Chassis		UXB + UXB + UXB	UXB + UXB + UXB	UXC + UXB + UXB
	Combination Unit		ARUM200LTE6 ARUM200LTE6 ARUM180LTE6	ARUM200LTE6 ARUM200LTE6 ARUM200LTE6	ARUM220LTE6 ARUM200LTE6 ARUM200LTE6
Power Supply	V / Ø / Hz		380-415 / 3 / 50	380-415 / 3 / 50	380-415 / 3 / 50
Cooling Capacity	Rated	kW	162.4	168.0	173.6
	Heating Capacity	Rated	kW	162.4	168.0
Heating Capacity	Max	kW	182.7	189.0	195.3
	Power Input (Cooling)	Rated	kW	49.47	52.62
Power Input (Heating)	Rated	kW	35.87	37.92	41.24
Efficiency	EER (Rated)	W/W	3.28	3.19	3.04
	COP (Rated)	W/W	4.53	4.43	4.21
	SEER	Wh/Wh	8.49	8.42	8.01
	SCOP	Wh/Wh	5.02	5.13	4.96
Outdoor Fan	Type		Propeller Fan	Propeller Fan	Propeller Fan
	Air Flow Rate (High)	m³/min x No.	(320 x 1) + (320 x 1) + (320 x 1)	(320 x 1) + (320 x 1) + (320 x 1)	(430 x 1) + (320 x 1) + (320 x 1)
	Discharge direction (Side / Top)		Top	Top	Top
Outdoor Fan Motor	Drive		Direct	Direct	Direct
	Output	W x No.	(900 x 2) + (900 x 2) + (900 x 2)	(900 x 2) + (900 x 2) + (900 x 2)	(1,500 x 2) + (900 x 2) + (900 x 2)
Compressor	Type		Hermetically Sealed Scroll	Hermetically Sealed Scroll	Hermetically Sealed Scroll
	Piston Displacement	cm³/rev	62.1 x 6	62.1 x 6	62.1 x 6
	Number of Revolution	rev./min	3,600 x 6	3,600 x 6	3,600 x 6
	Motor Output	W x No.	5,300 x 6	5,300 x 6	5,300 x 6
	Oil Type		FW68L (PVE)	FW68L (PVE)	FW68L (PVE)
Heat Exchanger	Fin Type		Wide Louver Plus	Wide Louver Plus	Wide Louver Plus
Dimensions	Net (W x H x D)	mm	(1,240 x 1,745 x 760) x 3	(1,240 x 1,745 x 760) x 3	((1,640 x 1,745 x 760) x 1) + ((1,240 x 1,745 x 760) x 2)
	Shipping (W x H x D)	mm	(1,282 x 1,919 x 802) x 3	(1,282 x 1,919 x 802) x 3	((1,675 x 1,919 x 802) x 1) + ((1,282 x 1,919 x 802) x 2)
Weight	Net	kg	(300 x 1) + (300 x 1) + (300 x 1)	(300 x 1) + (300 x 1) + (300 x 1)	(362 x 1) + (300 x 1) + (300 x 1)
	Shipping	kg	(310 x 1) + (310 x 1) + (310 x 1)	(310 x 1) + (310 x 1) + (310 x 1)	(372 x 1) + (310 x 1) + (310 x 1)
Refrigerant	Type		R410A	R410A	R410A
	Precharged Amount	kg	48.0	48.0	48.0
	t-CO ₂ eq.		100.200	100.200	100.200
	Control Type		EEV	EEV	EEV
Connecting Pipe	Liquid	mm (inch)	Ø19.05 (3/4)	Ø19.05 (3/4)	Ø22.20 (7/8)
	Gas	mm (inch)	Ø41.30 (1-5/8)	Ø41.30 (1-5/8)	Ø41.30 (1-5/8)
	Low Pressure Gas (Heat Recovery)	mm (inch)	Ø41.30 (1-5/8)	Ø41.30 (1-5/8)	Ø41.30 (1-5/8)
	High Pressure Gas (Heat Recovery)	mm (inch)	Ø34.90 (1-3/8)	Ø34.90 (1-3/8)	Ø34.90 (1-3/8)
Sound Pressure Level (Outdoor Unit)	Cooling	dB (A)	66.5	66.8	67.5
	Heating	dB (A)	67.8	68.3	69.3
Sound Power Level (Outdoor Unit)	Cooling	dB (A)	90.5	90.8	90.2
	Heating	dB (A)	93.0	93.8	93.5
Connecting Cable	Communication Cable (VCTF-SB)	mm² x cores	0.75 - 1.5 x 2C	0.75 - 1.5 x 2C	0.75 - 1.5 x 2C
Connectable Indoor Units Number	Max. (Conditional)	EA	64	64	64

1) Maximum numbers are prepared based on assumption that all 2.2kW indoor units are connected. The numbers in parentheses means maximum connectable indoor units in accordance with outdoor units combination (160% - 200%). The recommended ratio is 130%.

ARUM64OLTE6 / ARUM66OLTE6
ARUM68OLTE6



HP			64	66	68
Classification	Chassis		UXC + UXB + UXB	UXC + UXC + UXB	UXC + UXC + UXB
	Combination Unit		ARUM240LTE6 ARUM200LTE6 ARUM200LTE6	ARUM240LTE6 ARUM220LTE6 ARUM200LTE6	ARUM240LTE6 ARUM240LTE6 ARUM200LTE6
Power Supply	V / Ø / Hz		380-415 / 3 / 50	380-415 / 3 / 50	380-415 / 3 / 50
Cooling Capacity	Rated	kW	179.2	184.8	190.4
	Heating Capacity	Max	201.6	207.9	214.2
Power Input (Cooling)	Rated	kW	61.23	65.69	69.84
	Power Input (Heating)	Rated	kW	43.89	47.21
Efficiency	EER (Rated)	W/W	2.93	2.81	2.73
	COP (Rated)	W/W	4.08	3.91	3.82
	SEER	Wh/Wh	7.91	7.51	7.41
	SCOP	Wh/Wh	4.86	4.69	4.58
Outdoor Fan	Type		Propeller Fan	Propeller Fan	Propeller Fan
	Air Flow Rate (High)	m ³ /min x No.	(430 x 1) + (320 x 1) + (320 x 1)	(430 x 1) + (430 x 1) + (320 x 1)	(430 x 1) + (430 x 1) + (320 x 1)
	Discharge direction (Side / Top)		Top	Top	Top
Outdoor Fan Motor	Drive		Direct	Direct	Direct
	Output	W x No.	(1,500 x 2) + (900 x 2) + (900 x 2)	(1,500 x 2) + (1,500 x 2) + (900 x 2)	(1,500 x 2) + (1,500 x 2) + (900 x 2)
Compressor	Type		Hermetically Sealed Scroll	Hermetically Sealed Scroll	Hermetically Sealed Scroll
	Piston Displacement	cm ³ /rev	62.1 x 6	62.1 x 6	62.1 x 6
	Number of Revolution	rev./min	3,600 x 6	3,600 x 6	3,600 x 6
	Motor Output	W x No.	5,300 x 6	5,300 x 6	5,300 x 6
	Oil Type		FW68L (PVE)	FW68L (PVE)	FW68L (PVE)
Heat Exchanger	Fin Type		Wide Louver Plus	Wide Louver Plus	Wide Louver Plus
Dimensions	Net (W x H x D)	mm	((1,640 x 1,745 x 760) x 1) + ((1,240 x 1,745 x 760) x 2)	((1,640 x 1,745 x 760) x 2) + ((1,240 x 1,745 x 760) x 1)	((1,640 x 1,745 x 760) x 2) + ((1,240 x 1,745 x 760) x 1)
	Shipping (W x H x D)	mm	((1,675 x 1,919 x 802) x 1) + ((1,282 x 1,919 x 802) x 2)	((1,675 x 1,919 x 802) x 2) + ((1,282 x 1,919 x 802) x 1)	((1,675 x 1,919 x 802) x 2) + ((1,282 x 1,919 x 802) x 1)
Weight	Net	kg	(362 x 1) + (300 x 1) + (300 x 1)	(362 x 1) + (362 x 1) + (300 x 1)	(362 x 1) + (362 x 1) + (300 x 1)
	Shipping	kg	(372 x 1) + (310 x 1) + (310 x 1)	(372 x 1) + (372 x 1) + (310 x 1)	(372 x 1) + (372 x 1) + (310 x 1)
Refrigerant	Type		R410A	R410A	R410A
	Precharged Amount	kg	48.0	48.0	48.0
	t-CO ₂ eq.		100.200	100.200	100.200
	Control Type		EEV	EEV	EEV
Connecting Pipe	Liquid	mm (inch)	Ø22.20 (7/8)	Ø22.20 (7/8)	Ø22.20 (7/8)
	Gas	mm (inch)	Ø41.30 (1-5/8)	Ø53.98 (2-1/8)	Ø53.98 (2-1/8)
	Low Pressure Gas (Heat Recovery)	mm (inch)	Ø41.30 (1-5/8)	Ø53.98 (2-1/8)	Ø53.98 (2-1/8)
	High Pressure Gas (Heat Recovery)	mm (inch)	Ø34.90 (1-3/8)	Ø41.30 (1-5/8)	Ø41.30 (1-5/8)
Sound Pressure Level (Outdoor Unit)	Cooling	dB (A)	68.0	68.6	69.0
	Heating	dB (A)	69.3	70.1	70.1
Sound Power Level (Outdoor Unit)	Cooling	dB (A)	90.5	89.8	90.1
	Heating	dB (A)	93.5	93.1	93.1
Connecting Cable	Communication Cable (VCTF-SB)	mm ² x cores	0.75 - 1.5 x 2C	0.75 - 1.5 x 2C	0.75 - 1.5 x 2C
Connectable Indoor Units Number	Max. (Conditional)	EA	64	64	64

1) Maximum numbers are prepared based on assumption that all 2.2kW indoor units are connected. The numbers in parentheses means maximum connectable indoor units in accordance with outdoor units combination (160% - 200%). The recommended ratio is 130%.

ARUM70OLTE6 / ARUM72OLTE6
ARUM74OLTE6



HP			70	72	74
Classification	Chassis		UXB + UXB + UXB + UXA	UXB + UXB + UXB + UXA	UXB + UXB + UXB + UXB
	Combination Unit		ARUM200LTE6 ARUM200LTE6 ARUM180LTE6 ARUM120LTE6	ARUM200LTE6 ARUM200LTE6 ARUM200LTE6 ARUM120LTE6	ARUM200LTE6 ARUM200LTE6 ARUM200LTE6 ARUM140LTE6
Power Supply	V / Ø / Hz		380-415 / 3 / 50	380-415 / 3 / 50	380-415 / 3 / 50
Cooling Capacity	Rated	kW	196.0	201.6	207.2
	Heating Capacity	Max	220.5	226.8	233.1
Power Input (Cooling)	Rated	kW	61.12	64.27	64.50
	Power Input (Heating)	Rated	kW	43.64	45.69
Efficiency	EER (Rated)	W/W	3.21	3.14	3.21
	COP (Rated)	W/W	4.49	4.41	4.47
	SEER	Wh/Wh	8.36	8.30	8.45
	SCOP	Wh/Wh	5.01	5.09	5.14
Outdoor Fan	Type		Propeller Fan	Propeller Fan	Propeller Fan
	Air Flow Rate (High)	m ³ /min x No.	(320 x 1) + (320 x 1) + (320 x 1) + (220 x 1)	(320 x 1) + (320 x 1) + (320 x 1) + (220 x 1)	(320 x 1) + (320 x 1) + (320 x 1) + (320 x 1)
	Discharge direction (Side / Top)		Top	Top	Top
Outdoor Fan Motor	Drive		Direct	Direct	Direct
	Output	W x No.	(900 x 2) + (900 x 2) + (900 x 2) + (1,200 x 1)	(900 x 2) + (900 x 2) + (900 x 2) + (1,200 x 1)	(900 x 2) + (900 x 2) + (900 x 2) + (900 x 2)
Compressor	Type		Hermetically Sealed Scroll	Hermetically Sealed Scroll	Hermetically Sealed Scroll
	Piston Displacement	cm ³ /rev	62.1 x 7	62.1 x 7	62.1 x 7
	Number of Revolution	rev./min	3,600 x 7	3,600 x 7	3,600 x 7
	Motor Output	W x No.	5,300 x 7	5,300 x 7	5,300 x 7
	Oil Type		FW68L (PVE)	FW68L (PVE)	FW68L (PVE)
Heat Exchanger	Fin Type		Wide Louver Plus	Wide Louver Plus	Wide Louver Plus
Dimensions	Net (W x H x D)	mm	((1,240 x 1,745 x 760) x 3) + ((930 x 1,745 x 760) x 1)	((1,240 x 1,745 x 760) x 3) + ((930 x 1,745 x 760) x 1)	(1,240 x 1,745 x 760) x 4
	Shipping (W x H x D)	mm	((1,282 x 1,919 x 802) x 3) + ((965 x 1,919 x 802) x 1)	((1,282 x 1,919 x 802) x 3) + ((965 x 1,919 x 802) x 1)	(1,282 x 1,919 x 802) x 4
Weight	Net	kg	(300 x 1) + (300 x 1) + (300 x 1) + (215 x 1)	(300 x 1) + (300 x 1) + (300 x 1) + (215 x 1)	(300 x 1) + (300 x 1) + (300 x 1) + (255 x 1)
	Shipping	kg	(310 x 1) + (310 x 1) + (310 x 1) + (225 x 1)	(310 x 1) + (310 x 1) + (310 x 1) + (225 x 1)	(310 x 1) + (310 x 1) + (310 x 1) + (265 x 1)
Refrigerant	Type		R410A	R410A	R410A
	Precharged Amount	kg	57.5	57.5	61.0
	t-CO ₂ eq.		120.031	120.031	127.338
	Control Type		EEV	EEV	EEV
Connecting Pipe	Liquid	mm (inch)	Ø22.20 (7/8)	Ø22.20 (7/8)	Ø22.20 (7/8)
	Gas	mm (inch)	Ø53.98 (2-1/8)	Ø53.98 (2-1/8)	Ø53.98 (2-1/8)
	Low Pressure Gas (Heat Recovery)	mm (inch)	Ø53.98 (2-1/8)	Ø53.98 (2-1/8)	Ø53.98 (2-1/8)
	High Pressure Gas (Heat Recovery)	mm (inch)	Ø41.30 (1-5/8)	Ø41.30 (1-5/8)	Ø41.30 (1-5/8)
Sound Pressure Level (Outdoor Unit)	Cooling	dB (A)	67.2	67.4	67.6
	Heating	dB (A)	68.5	68.9	69.0
Sound Power Level (Outdoor Unit)	Cooling	dB (A)	90.8	91.1	91.2
	Heating	dB (A)	93.3	94.1	94.0
Connecting Cable	Communication Cable (VCTF-SB)	mm ² x cores	0.75 - 1.5 x 2C	0.75 - 1.5 x 2C	0.75 - 1.5 x 2C
Connectable Indoor Units Number	Max. (Conditional)	EA	64	64	64

1) Maximum numbers are prepared based on assumption that all 2.2kW indoor units are connected. The numbers in parentheses means maximum connectable indoor units in accordance with outdoor units combination (160% - 200%). The recommended ratio is 130%.

ARUM760LTE6 / ARUM780LTE6
ARUM800LTE6

HP			76	78	80
Classification	Chassis		UXB + UXB + UXB + UXB	UXB + UXB + UXB + UXB	UXB + UXB + UXB + UXB
	Combination Unit		ARUM200LTE6 ARUM200LTE6 ARUM200LTE6 ARUM160LTE6	ARUM200LTE6 ARUM200LTE6 ARUM200LTE6 ARUM180LTE6	ARUM200LTE6 ARUM200LTE6 ARUM200LTE6 ARUM200LTE6
Power Supply	V / Ø / Hz		380-415 / 3 / 50	380-415 / 3 / 50	380-415 / 3 / 50
Cooling Capacity	Rated	kW	212.8	218.4	224.0
	Heating Capacity	Rated	kW	212.8	218.4
Power Input (Cooling)	Rated	kW	68.07	67.01	70.16
	Rated	kW	48.01	48.51	50.56
Efficiency	EER (Rated)	W/W	3.13	3.26	3.19
	COP (Rated)	W/W	4.43	4.50	4.43
	SEER	Wh/Wh	8.30	8.47	8.42
	SCOP	Wh/Wh	5.21	5.05	5.13
Outdoor Fan	Type		Propeller Fan	Propeller Fan	Propeller Fan
	Air Flow Rate (High)	m ³ /min x No.	(320 × 1) + (320 × 1) + (320 × 1) + (320 × 1)	(320 × 1) + (320 × 1) + (320 × 1) + (320 × 1)	(320 × 1) + (320 × 1) + (320 × 1) + (320 × 1)
	Discharge direction (Side / Top)		Top	Top	Top
Outdoor Fan Motor	Drive		Direct	Direct	Direct
	Output	W x No.	(900 × 2) + (900 × 2) + (900 × 2) + (900 × 2)	(900 × 2) + (900 × 2) + (900 × 2) + (900 × 2)	(900 × 2) + (900 × 2) + (900 × 2) + (900 × 2)
Compressor	Type		Hermetically Sealed Scroll	Hermetically Sealed Scroll	Hermetically Sealed Scroll
	Piston Displacement	cm ³ /rev	62.1 × 7	62.1 × 8	62.1 × 8
	Number of Revolution	rev./min	3,600 × 7	3,600 × 8	3,600 × 8
	Motor Output	W x No.	5,300 × 7	5,300 × 8	5,300 × 8
Heat Exchanger	Oil Type		FW68L (PVE)	FW68L (PVE)	FW68L (PVE)
	Fin Type		Wide Louver Plus	Wide Louver Plus	Wide Louver Plus
Dimensions	Net (W x H x D)	mm	(1,240 × 1,745 × 760) × 4	(1,240 × 1,745 × 760) × 4	(1,240 × 1,745 × 760) × 4
	Shipping (W x H x D)	mm	(1,282 × 1,919 × 802) × 4	(1,282 × 1,919 × 802) × 4	(1,282 × 1,919 × 802) × 4
Weight	Net	kg	(300 × 1) + (300 × 1) + (300 × 1) + (255 × 1)	(300 × 1) + (300 × 1) + (300 × 1) + (300 × 1)	(300 × 1) + (300 × 1) + (300 × 1) + (300 × 1)
	Shipping	kg	(310 × 1) + (310 × 1) + (310 × 1) + (265 × 1)	(310 × 1) + (310 × 1) + (310 × 1) + (310 × 1)	(310 × 1) + (310 × 1) + (310 × 1) + (310 × 1)
Refrigerant	Type		R410A	R410A	R410A
	Precharged Amount	kg	61.0	64.0	64.0
	t-CO ₂ eq.		127.338	133.600	133.600
	Control Type		EEV	EEV	EEV
Connecting Pipe	Liquid	mm (inch)	Ø22.20 (7/8)	Ø22.20 (7/8)	Ø22.20 (7/8)
	Gas	mm (inch)	Ø53.98 (2-1/8)	Ø53.98 (2-1/8)	Ø53.98 (2-1/8)
	Low Pressure Gas (Heat Recovery)	mm (inch)	Ø53.98 (2-1/8)	Ø53.98 (2-1/8)	Ø53.98 (2-1/8)
	High Pressure Gas (Heat Recovery)	mm (inch)	Ø41.30 (1-5/8)	Ø41.30 (1-5/8)	Ø41.30 (1-5/8)
Sound Pressure Level (Outdoor Unit)	Cooling	dB (A)	67.7	67.8	68.0
	Heating	dB (A)	69.1	69.2	69.5
Sound Power Level (Outdoor Unit)	Cooling	dB (A)	91.8	91.8	92.0
	Heating	dB (A)	94.3	94.4	95.0
Connecting Cable	Communication Cable (VCTF-SB)	mm ² x cores	0.75 - 1.5 x 2C	0.75 - 1.5 x 2C	0.75 - 1.5 x 2C
Connectable Indoor Units Number	Max. (Conditional)	EA	64	64	64

1) Maximum numbers are prepared based on assumption that all 2.2kW indoor units are connected. The numbers in parentheses means maximum connectable indoor units in accordance with outdoor units combination (160% - 200%). The recommended ratio is 130%.

ARUM820LTE6 / ARUM840LTE6



HP			82	84
Classification	Chassis		UXC + UXC + UXB + UXB	UXC + UXC + UXB + UXB
	Combination Unit		ARUM240LTE6 ARUM240LTE6 ARUM200LTE6 ARUM140LTE6	ARUM240LTE6 ARUM240LTE6 ARUM200LTE6 ARUM160LTE6
Power Supply	V / Ø / Hz		380-415 / 3 / 50	380-415 / 3 / 50
Cooling Capacity	Rated	kW	229.6	235.2
	Heating Capacity	Rated	kW	229.6
Power Input (Cooling)	Rated	kW	81.72	85.29
	Rated	kW	58.29	59.95
Efficiency	EER (Rated)	W/W	2.81	2.76
	COP (Rated)	W/W	3.94	3.92
	SEER	Wh/Wh	7.70	7.55
	SCOP	Wh/Wh	4.73	4.80
Outdoor Fan	Type		Propeller Fan	Propeller Fan
	Air Flow Rate (High)	m ³ /min x No.	(430 × 1) + (430 × 1) + (320 × 1) + (320 × 1)	(430 × 1) + (430 × 1) + (320 × 1) + (320 × 1)
	Discharge direction (Side / Top)		Top	Top
Outdoor Fan Motor	Drive		Direct	Direct
	Output	W x No.	(1,500 × 2) + (1,500 × 2) + (900 × 2) + (900 × 2)	(1,500 × 2) + (1,500 × 2) + (900 × 2) + (900 × 2)
Compressor	Type		Hermetically Sealed Scroll	Hermetically Sealed Scroll
	Piston Displacement	cm ³ /rev	62.1 × 7	62.1 × 7
	Number of Revolution	rev./min	3,600 × 7	3,600 × 7
	Motor Output	W x No.	5,300 × 7	5,300 × 7
Heat Exchanger	Oil Type		FW68L (PVE)	FW68L (PVE)
	Fin Type		Wide Louver Plus	Wide Louver Plus
Dimensions	Net (W x H x D)	mm	((1,640 × 1,745 × 760) × 2) + ((1,240 × 1,745 × 760) × 2)	((1,640 × 1,745 × 760) × 2) + ((1,240 × 1,745 × 760) × 2)
	Shipping (W x H x D)	mm	((1,675 × 1,919 × 802) × 2) + ((1,282 × 1,919 × 802) × 2)	((1,675 × 1,919 × 802) × 2) + ((1,282 × 1,919 × 802) × 2)
Weight	Net	kg	(362 × 1) + (362 × 1) + (300 × 1) + (255 × 1)	(362 × 1) + (362 × 1) + (300 × 1) + (255 × 1)
	Shipping	kg	(372 × 1) + (372 × 1) + (310 × 1) + (265 × 1)	(372 × 1) + (372 × 1) + (310 × 1) + (265 × 1)
Refrigerant	Type		R410A	R410A
	Precharged Amount	kg	61.0	61.0
	t-CO ₂ eq.		127.338	127.338
Connecting Pipe	Control Type		EEV	EEV
	Liquid	mm (inch)	Ø22.20 (7/8)	Ø22.20 (7/8)
	Gas	mm (inch)	Ø53.98 (2-1/8)	Ø53.98 (2-1/8)
	Low Pressure Gas (Heat Recovery)	mm (inch)	Ø53.98 (2-1/8)	Ø53.98 (2-1/8)
Sound Pressure Level (Outdoor Unit)	Cooling	dB (A)	69.5	69.6
	Heating	dB (A)	70.6	70.6
Sound Power Level (Outdoor Unit)	Cooling	dB (A)	90.6	91.3
	Heating	dB (A)	93.4	93.8
Connecting Cable	Communication Cable (VCTF-SB)	mm ² x cores	0.75 - 1.5 x 2C	0.75 - 1.5 x 2C
Connectable Indoor Units Number	Max. (Conditional)	EA	64	64

1) Maximum numbers are prepared based on assumption that all 2.2kW indoor units are connected. The numbers in parentheses means maximum connectable indoor units in accordance with outdoor units combination (160% - 200%). The recommended ratio is 130%.

ARUM860LTE6 / ARUM880LTE6



HP			86	88
Classification	Chassis		UXC + UXC + UXB + UXB	UXC + UXC + UXB + UXB
	Combination Unit		ARUM240LTE6 ARUM240LTE6 ARUM200LTE6 ARUM180LTE6	ARUM240LTE6 ARUM240LTE6 ARUM200LTE6 ARUM200LTE6
Power Supply	V / Ø / Hz		380-415 / 3 / 50	380-415 / 3 / 50
Cooling Capacity	Rated	kW	240.8	246.4
	Max	kW	270.9	277.2
Heating Capacity	Rated	kW	240.8	246.4
	Max	kW	270.9	277.2
Power Input (Cooling)	Rated	kW	84.23	87.38
Power Input (Heating)	Rated	kW	60.45	62.50
Efficiency	EER (Rated)	W/W	2.86	2.82
	COP (Rated)	W/W	3.98	3.94
	SEER	Wh/Wh	7.72	7.66
	SCOP	Wh/Wh	4.64	4.72
Outdoor Fan	Type		Propeller Fan	Propeller Fan
	Air Flow Rate (High)	m³/min x No.	(430 x 1) + (430 x 1) + (320 x 1) + (320 x 1)	(430 x 1) + (430 x 1) + (320 x 1) + (320 x 1)
Outdoor Fan Motor	Discharge direction (Side / Top)		Top	Top
	Drive		Direct	Direct
Compressor	Output	W x No.	(1,500 x 2) + (1,500 x 2) + (900 x 2) + (900 x 2)	(1,500 x 2) + (1,500 x 2) + (900 x 2) + (900 x 2)
	Type		Hermetically Sealed Scroll	Hermetically Sealed Scroll
	Piston Displacement	cm³/rev	62.1 x 8	62.1 x 8
	Number of Revolution	rev./min	3,600 x 8	3,600 x 8
	Motor Output	W x No.	5,300 x 8	5,300 x 8
	Oil Type		FW68L (PVE)	FW68L (PVE)
Heat Exchanger	Fin Type		Wide Louver Plus	Wide Louver Plus
	Net (W x H x D)	mm	((1,640 x 1,745 x 760) x 2) + ((1,240 x 1,745 x 760) x 2)	((1,640 x 1,745 x 760) x 2) + ((1,240 x 1,745 x 760) x 2)
Dimensions	Shipping (W x H x D)	mm	((1,675 x 1,919 x 802) x 2) + ((1,282 x 1,919 x 802) x 2)	((1,675 x 1,919 x 802) x 2) + ((1,282 x 1,919 x 802) x 2)
	Net	kg	(362 x 1) + (362 x 1) + (300 x 1) + (300 x 1)	(362 x 1) + (362 x 1) + (300 x 1) + (300 x 1)
Weight	Shipping	kg	(372 x 1) + (372 x 1) + (310 x 1) + (310 x 1)	(372 x 1) + (372 x 1) + (310 x 1) + (310 x 1)
	Type		R410A	R410A
Refrigerant	Precharged Amount	kg	64.0	64.0
	t-CO ₂ eq.		133.600	133.600
	Control Type		EEV	EEV
Connecting Pipe	Liquid	mm (inch)	Ø22.20 (7/8)	Ø22.20 (7/8)
	Gas	mm (inch)	Ø53.98 (2-1/8)	Ø53.98 (2-1/8)
	Low Pressure Gas (Heat Recovery)	mm (inch)	Ø53.98 (2-1/8)	Ø53.98 (2-1/8)
	High Pressure Gas (Heat Recovery)	mm (inch)	Ø41.30 (1-5/8)	Ø41.30 (1-5/8)
Sound Pressure Level (Outdoor Unit)	Cooling	dB (A)	69.6	69.8
	Heating	dB (A)	70.7	70.9
Sound Power Level (Outdoor Unit)	Cooling	dB (A)	91.3	91.5
	Heating	dB (A)	93.9	94.5
Connecting Cable	Communication Cable (VCTF-SB)	mm² x cores	0.75 - 1.5 x 2C	0.75 - 1.5 x 2C
Connectable Indoor Units Number	Max. (Conditional)	EA	64	64

1) Maximum numbers are prepared based on assumption that all 2.2kW indoor units are connected. The numbers in parentheses means maximum connectable indoor units in accordance with outdoor units combination (160% - 200%). The recommended ratio is 130%.

ARUM900LTE6 / ARUM920LTE6



HP			90	92
Classification	Chassis		UXC + UXC + UXC + UXB	UXC + UXC + UXC + UXC
	Combination Unit		ARUM240LTE6 ARUM240LTE6 ARUM220LTE6 ARUM200LTE6	ARUM240LTE6 ARUM240LTE6 ARUM220LTE6 ARUM220LTE6
Power Supply	V / Ø / Hz		380-415 / 3 / 50	380-415 / 3 / 50
Cooling Capacity	Rated	kW	252.0	257.6
	Max	kW	283.5	289.8
Heating Capacity	Rated	kW	252.0	257.6
	Max	kW	283.5	289.8
Power Input (Cooling)	Rated	kW	91.84	96.30
Power Input (Heating)	Rated	kW	65.82	69.14
Efficiency	EER (Rated)	W/W	2.74	2.67
	COP (Rated)	W/W	3.83	3.73
	SEER	Wh/Wh	7.36	7.06
	SCOP	Wh/Wh	4.59	4.47
Outdoor Fan	Type		Propeller Fan	Propeller Fan
	Air Flow Rate (High)	m³/min x No.	(430 x 1) + (430 x 1) + (430 x 1) + (320 x 1)	(430 x 1) + (430 x 1) + (430 x 1) + (430 x 1)
Outdoor Fan Motor	Discharge direction (Side / Top)		Top	Top
	Drive		Direct	Direct
Compressor	Output	W x No.	(1,500 x 2) + (1,500 x 2) + (1,500 x 2) + (900 x 2)	(1,500 x 2) + (1,500 x 2) + (1,500 x 2) + (1,500 x 2)
	Type		Hermetically Sealed Scroll	Hermetically Sealed Scroll
	Piston Displacement	cm³/rev	62.1 x 8	62.1 x 8
	Number of Revolution	rev./min	3,600 x 8	3,600 x 8
	Motor Output	W x No.	5,300 x 8	5,300 x 8
	Oil Type		FW68L (PVE)	FW68L (PVE)
Heat Exchanger	Fin Type		Wide Louver Plus	Wide Louver Plus
	Net (W x H x D)	mm	((1,640 x 1,745 x 760) x 3) + ((1,240 x 1,745 x 760) x 1)	(1,640 x 1,745 x 760) x 4
Dimensions	Shipping (W x H x D)	mm	((1,675 x 1,919 x 802) x 3) + ((1,282 x 1,919 x 802) x 1)	(1,675 x 1,919 x 802) x 4
	Net	kg	(362 x 1) + (362 x 1) + (362 x 1) + (300 x 1)	(362 x 1) + (362 x 1) + (362 x 1) + (362 x 1)
Weight	Shipping	kg	(372 x 1) + (372 x 1) + (372 x 1) + (310 x 1)	(372 x 1) + (372 x 1) + (372 x 1) + (372 x 1)
	Type		R410A	R410A
Refrigerant	Precharged Amount	kg	64.0	64.0
	t-CO ₂ eq.		133.600	133.600
	Control Type		EEV	EEV
Connecting Pipe	Liquid	mm (inch)	Ø22.20 (7/8)	Ø22.20 (7/8)
	Gas	mm (inch)	Ø53.98 (2-1/8)	Ø53.98 (2-1/8)
	Low Pressure Gas (Heat Recovery)	mm (inch)	Ø53.98 (2-1/8)	Ø53.98 (2-1/8)
	High Pressure Gas (Heat Recovery)	mm (inch)	Ø41.30 (1-5/8)	Ø41.30 (1-5/8)
Sound Pressure Level (Outdoor Unit)	Cooling	dB (A)	70.2	70.5
	Heating	dB (A)	71.5	72.0
Sound Power Level (Outdoor Unit)	Cooling	dB (A)	91.1	90.5
	Heating	dB (A)	94.3	94.0
Connecting Cable	Communication Cable (VCTF-SB)	mm² x cores	0.75 - 1.5 x 2C	0.75 - 1.5 x 2C
Connectable Indoor Units Number	Max. (Conditional)	EA	64	64

1) Maximum numbers are prepared based on assumption that all 2.2kW indoor units are connected. The numbers in parentheses means maximum connectable indoor units in accordance with outdoor units combination (160% - 200%). The recommended ratio is 130%.

ARUM94OLTE6 / ARUM96OLTE6



HP			94	96
Classification	Chassis		UXC + UXC + UXC + UXC	UXC + UXC + UXC + UXC
	Combination Unit		ARUM240LTE6 ARUM240LTE6 ARUM240LTE6 ARUM220LTE6	ARUM240LTE6 ARUM240LTE6 ARUM240LTE6 ARUM240LTE6
Power Supply	V / Ø / Hz		380-415 / 3 / 50	380-415 / 3 / 50
Cooling Capacity	Rated	kW	263.2	268.8
	Max	kW	296.1	302.4
Heating Capacity	Rated	kW	263.2	268.8
	Max	kW	296.1	302.4
Power Input (Cooling)	Rated	kW	100.50	104.60
Power Input (Heating)	Rated	kW	71.79	74.44
Efficiency	EER (Rated)	W/W	2.62	2.57
	COP (Rated)	W/W	3.67	3.61
	SEER	Wh/Wh	6.98	6.91
	SCOP	Wh/Wh	4.39	4.31
Outdoor Fan	Type		Propeller Fan	Propeller Fan
	Air Flow Rate (High)	m ³ /min x No.	(430 x 1) + (430 x 1) + (430 x 1) + (430 x 1)	(430 x 1) + (430 x 1) + (430 x 1) + (430 x 1)
	Discharge direction (Side / Top)		Top	Top
Outdoor Fan Motor	Drive		Direct	Direct
	Output	W x No.	(1,500 x 2) + (1,500 x 2) + (1,500 x 2) + (1,500 x 2)	(1,500 x 2) + (1,500 x 2) + (1,500 x 2) + (1,500 x 2)
Compressor	Type		Hermetically Sealed Scroll	Hermetically Sealed Scroll
	Piston Displacement	cm ³ /rev	62.1 x 8	62.1 x 8
	Number of Revolution	rev./min	3,600 x 8	3,600 x 8
	Motor Output	W x No.	5,300 x 8	5,300 x 8
	Oil Type		FW68L (PVE)	FW68L (PVE)
Heat Exchanger	Fin Type		Wide Louver Plus	Wide Louver Plus
Dimensions	Net (W x H x D)	mm	(1,640 x 1,745 x 760) x 4	(1,640 x 1,745 x 760) x 4
	Shipping (W x H x D)	mm	(1,675 x 1,919 x 802) x 4	(1,675 x 1,919 x 802) x 4
Weight	Net	kg	(362 x 1) + (362 x 1) + (362 x 1) + (362 x 1)	(362 x 1) + (362 x 1) + (362 x 1) + (362 x 1)
	Shipping	kg	(372 x 1) + (372 x 1) + (372 x 1) + (372 x 1)	(372 x 1) + (372 x 1) + (372 x 1) + (372 x 1)
Refrigerant	Type		R410A	R410A
	Precharged Amount	kg	64.0	64.0
	t-CO ₂ eq.		133.600	133.600
	Control Type		EEV	EEV
Connecting Pipe	Liquid	mm (inch)	Ø22.20 (7/8)	Ø22.20 (7/8)
	Gas	mm (inch)	Ø53.98 (2-1/8)	Ø53.98 (2-1/8)
	Low Pressure Gas (Heat Recovery)	mm (inch)	Ø53.98 (2-1/8)	Ø53.98 (2-1/8)
	High Pressure Gas (Heat Recovery)	mm (inch)	Ø41.30 (1-5/8)	Ø41.30 (1-5/8)
Sound Pressure Level (Outdoor Unit)	Cooling	dB (A)	70.8	71.0
	Heating	dB (A)	72.0	72.0
Sound Power Level (Outdoor Unit)	Cooling	dB (A)	90.8	91.0
	Heating	dB (A)	94.0	94.0
Connecting Cable	Communication Cable (VCTF-SB)	mm ² x cores	0.75 - 1.5 x 2C	0.75 - 1.5 x 2C
Connectable Indoor Units Number	Max. (Conditional)	EA	64	64

1) Maximum numbers are prepared based on assumption that all 2.2kW indoor units are connected. The numbers in parentheses means maximum connectable indoor units in accordance with outdoor units combination (160% - 200%). The recommended ratio is 130%.

1. Eurovent Test Condition : For more info regarding program consult www.eurovent-certification.com

2. Capacities are based on the following conditions :

- Cooling : Indoor 27°C (80.6°F) DB / 19°C (66.2°F) WB Outdoor 35°C (95°F) DB / 24°C (75.2°F) WB
- Heating : Indoor 20°C (68°F) DB / 15°C (59°F) WB Outdoor 7°C (44.6°F) DB / 6°C (42.8°F) WB
- Piping Length : Interconnected Pipe Length = 7.5m
- Elevation Difference (Outdoor ~ Indoor Unit) is 0m.

3. Wiring cable size must comply with the applicable local and national code.

4. Sound pressure level is measured on the rated condition in the anechoic rooms by ISO 3745 standard. Refer to the model specifications for nominal conditions. (Power source and Ambient temperature, etc) Sound levels can be increased in accordance with installation and operating conditions. (Operating conditions include some functional condition like Static Pressure mode, air guide use, Room target temperature setting, etc and these functions are different in accordance with each model.) Sound level will vary depending on a range of factors such as the construction(acoustic absorption coefficient) of particular room in which the equipment in installed.

5. Explanation of Terms

- EER : Energy Efficiency Ratio (Cooling)
- SEER : Seasonal Energy Efficiency Ratio (Refer to Typical Cooling Season)
- COP : Coefficient Of Performance (Heating)
- SCOP : Seasonal Coefficient Of Performance (Refer to Typical Heating Season)

6. Due to our policy of innovation some specifications may be changed without notification.

7. This product contains Fluorinated greenhouse gas. (R410A, GWP (Global warming potential) = 2,087.5)